

# *Weather-Rite LLC*

## *TT-Series Direct-Fired Air Handlers*



## *Dimension and Selection Guide*

**1.800.589.3691**  
**[www.weather-rite.com](http://www.weather-rite.com)**



CANADA: 100% OUTSIDE AIR ONLY

# TT-112 and TT-115 Horizontal Model Dimensions

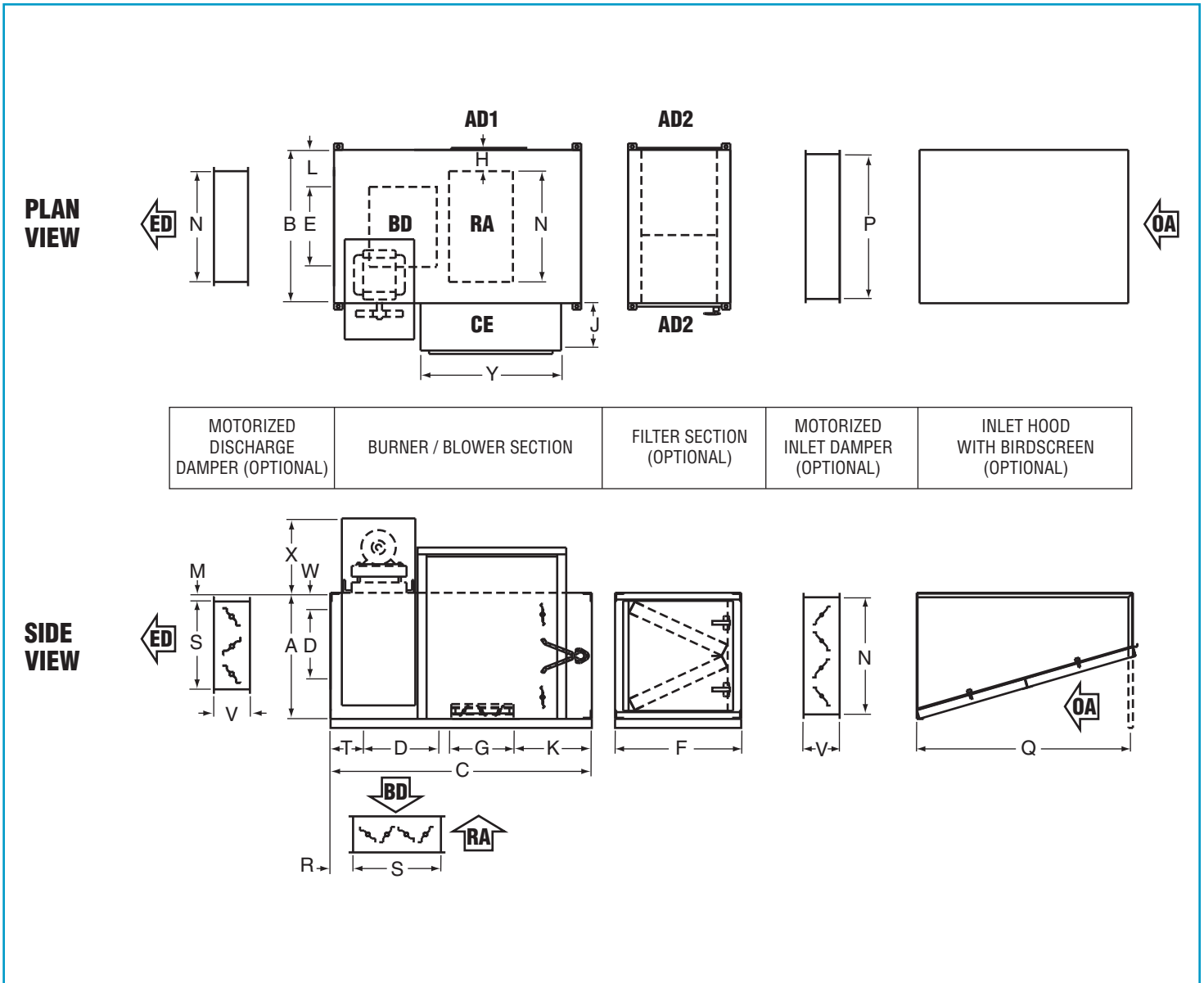

## CABINET DIMENSIONS

MODEL	A	B	C	D	E	F	G	H	J	K	L	M	N	P	Q	R	S	T	W	X	Y	V
TT-112	28.0	36.0	58.0	13.4	15.6	24.0	15.0	5.0	17.2	16.0	10.2	1.0	26.0	34.0	48.0	5.0	19.5	7.0	1.0	18.5	33.0	8.0
TT-115	28.0	36.0	58.0	15.9	18.6	24.0	15.0	5.0	17.2	16.0	8.9	1.0	26.0	34.0	48.0	5.0	19.5	8.3	3.8	18.5	33.0	8.0

## FILTERS\*

MODEL	FILTER SECTION
TT-112	3 - 2 x 20 x 20 3 - 2 x 16 x 20
TT-115	3 - 2 x 20 x 20 3 - 2 x 16 x 20

\*Permanent, Polyester or Pleated

## LEGEND

<b>RA</b> = Return Air	<b>BD</b> = Bottom Discharge
<b>OA</b> = Outside Air	<b>ED</b> = End Discharge
<b>CE</b> = Control Enclosure	<b>AD2</b> = Filter Access Door
<b>AD1</b> = Unit Access Door	<b>TD</b> = Top Discharge
<b>SD</b> = Side Discharge	

## IMPORTANT NOTES:

- All dimensions are in inches.
- All weights are in pounds.
- Shipping weights apply to both horizontal and upright models.
- All dimensions and weights are subject to change without notice.
- Some components may ship separately due to shipping constraints.
- Units only supplied with left-handed controls as shown.
- TT-112 and TT-115 inlet hoods must be supported.
- Dimensions for filter sections only apply to those sections using permanent, polyester or pleated filters. Contact Weather-Rite, LLC for dimensions of sections using bag or cartridge filters.

# TT-112 and TT-115 Upright Model Dimensions

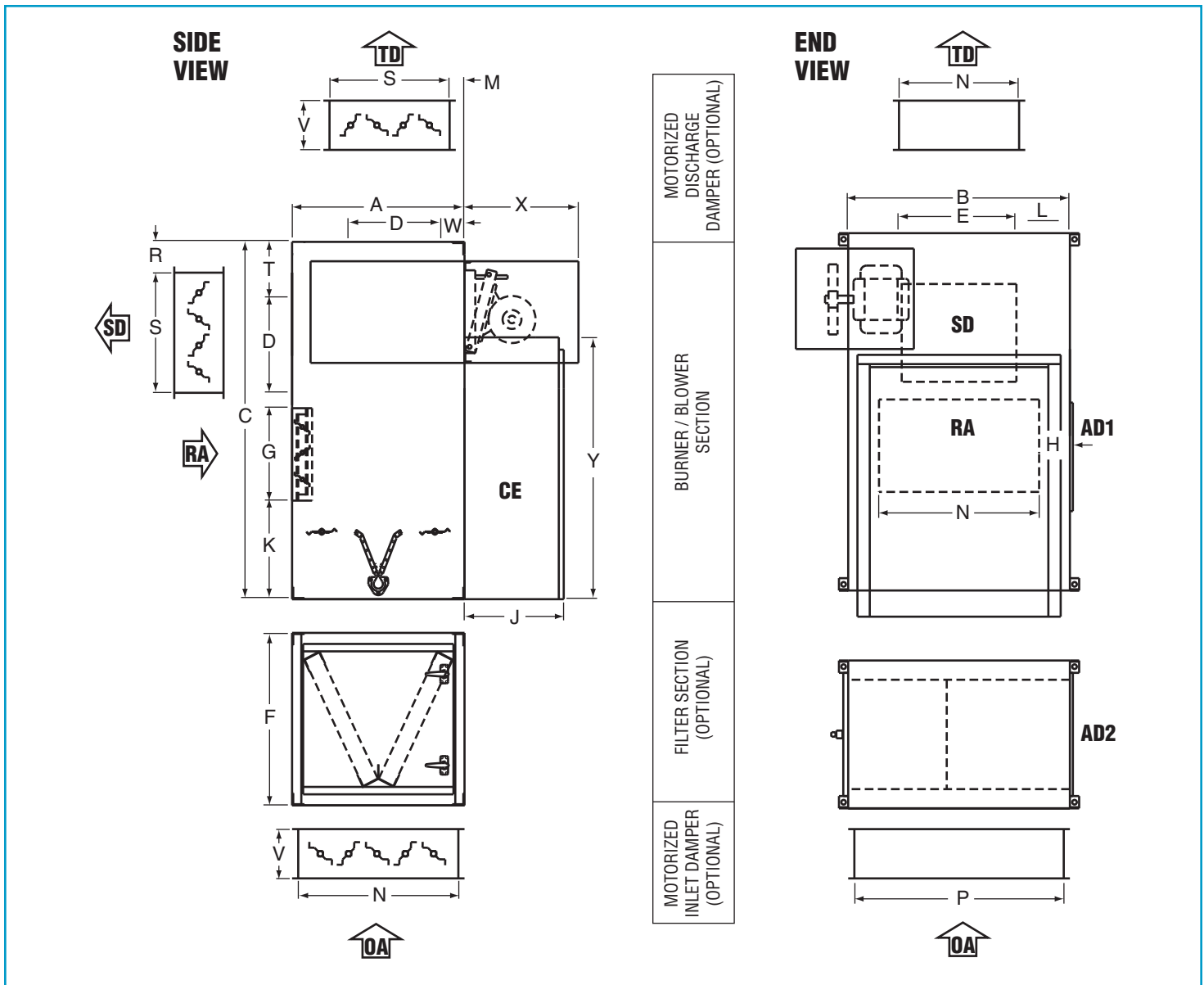

## ESTIMATED SHIPPING WEIGHTS

MODEL	BURNER / BLOWER SECTION	FILTER SECTION	INLET HOOD	WEATHERIZING	DISCHARGE OR INLET DAMPER
TT-112	400	63	30	75	40
TT-115	525	63	30	75	40

## ESTIMATED SHIPPING WEIGHTS - MOTORS

SIZE HP	.75	1	1.5	2	3	5	7.5	10	15	20	25	30	40	50	60	75
STD WEIGHT	35	35	45	45	70	85	130	155	220	275	300	360	500	550	800	950
2-SP WEIGHT	70	85	125	150	185	215	270	310	405	455	525	570	700	760	N/A	N/A

# TT-118 Horizontal Model Dimensions

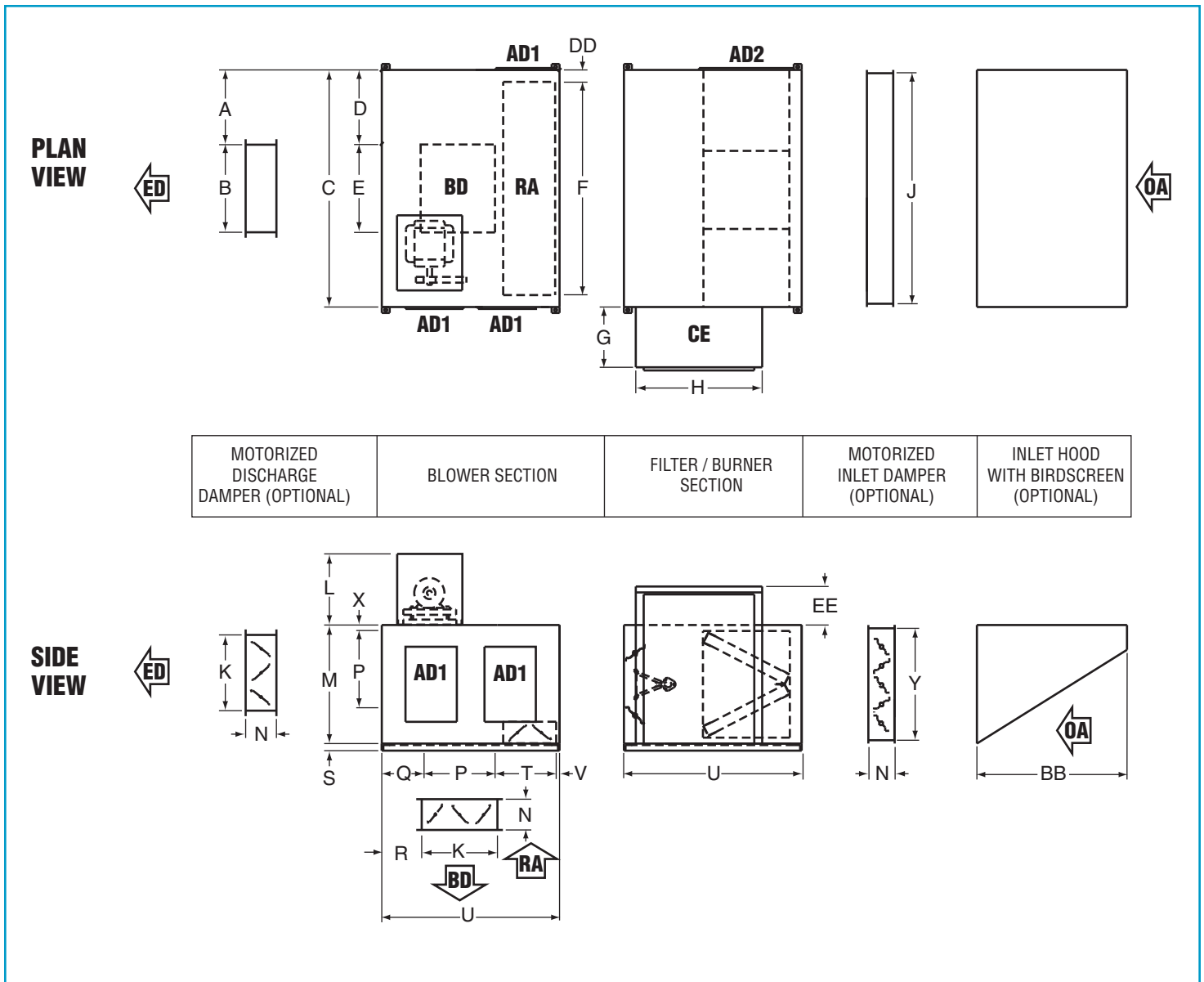

CABINET DIMENSIONS																									
MODEL	A	B	C	D	E	F	G	H	J	K	L	M	N	P	Q	R	S	T	U	V	X	Y	BB	DD	EE
TT-118	17.0	26.0	60.0	19.1	21.9	50.0	16.2	33.0	58.0	19.5	18.0	30.0	8.0	18.9	10.4	10.3	2.0	12.0	45.0	1.9	0.8	28.0	38.0	5.0	10.0

FILTERS*	
MODEL	FILTER SECTION
TT-118	6 - 2 x 20 x 25

\*Permanent, Polyester or Pleated

LEGEND	
RA = Return Air	BD = Bottom Discharge
OA = Outside Air	ED = End Discharge
CE = Control Enclosure	AD2 = Filter Access Door
AD1 = Unit Access Door	TD = Top Discharge
SD = Side Discharge	

## IMPORTANT NOTES:

- All dimensions are in inches.
- All weights are in pounds.
- Shipping weights apply to both horizontal and upright models.
- All dimensions and weights are subject to change without notice.
- Some components may ship separately due to shipping constraints.
- Units only supplied with left-handed controls as shown.
- Dimensions for filter sections only apply to those sections using permanent, polyester or pleated filters. Contact Weather-Rite, LLC for dimensions of sections using bag or cartridge filters.

# TT-118 Upright Model Dimensions

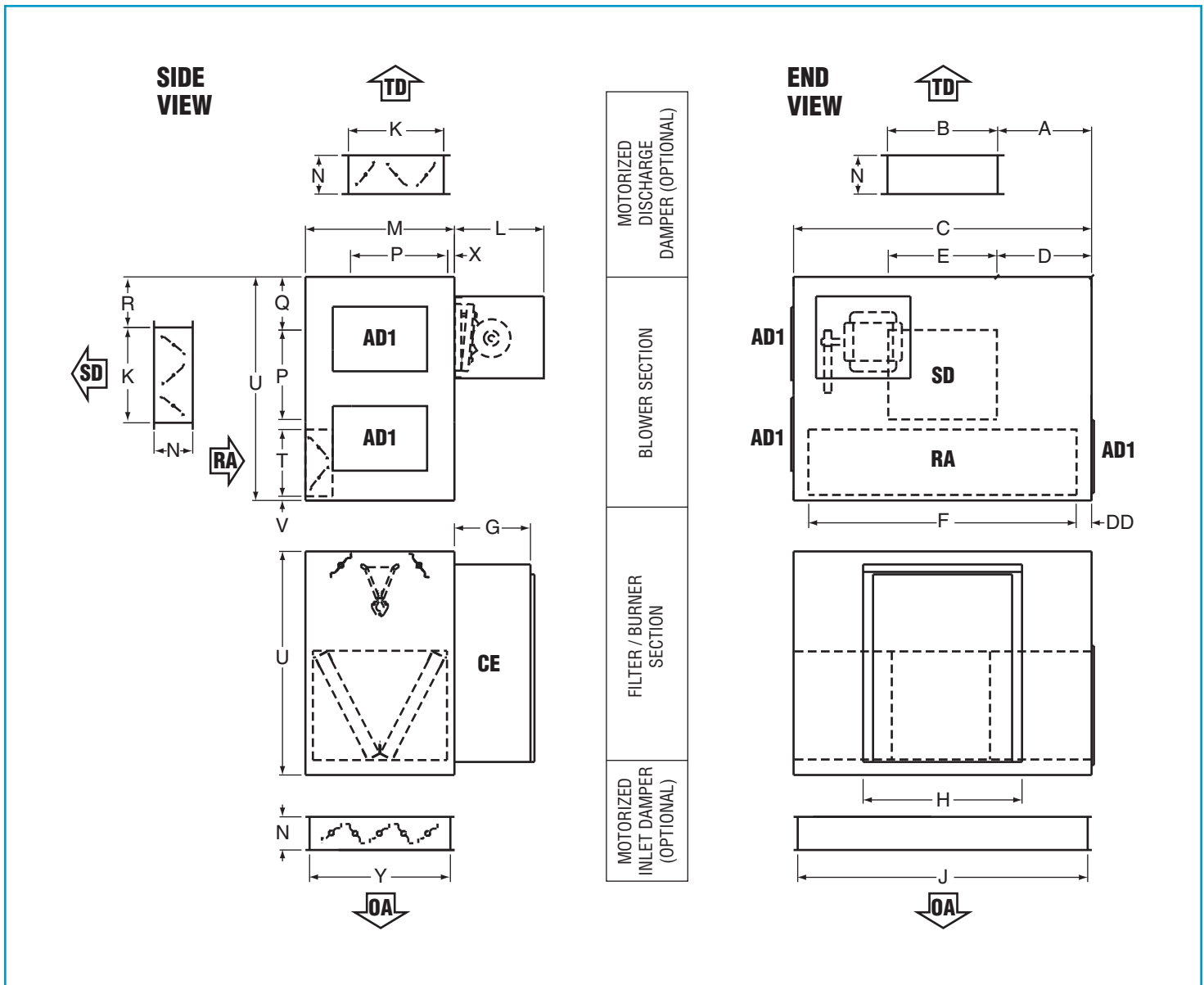

## ESTIMATED SHIPPING WEIGHTS

MODEL	BURNER / BLOWER / FILTER SECTION	INLET HOOD	WEATHERIZING	DISCHARGE OR INLET DAMPER
TT-118	700	55	75	70

## ESTIMATED SHIPPING WEIGHTS - MOTORS

SIZE HP	.75	1	1.5	2	3	5	7.5	10	15	20	25	30	40	50	60	75
STD WEIGHT	35	35	45	45	70	85	130	155	220	275	300	360	500	550	800	950
2-SP WEIGHT	70	85	125	150	185	215	270	310	405	455	525	570	700	760	N/A	N/A

# TT-212 through TT-221 Horizontal Model Dimensions

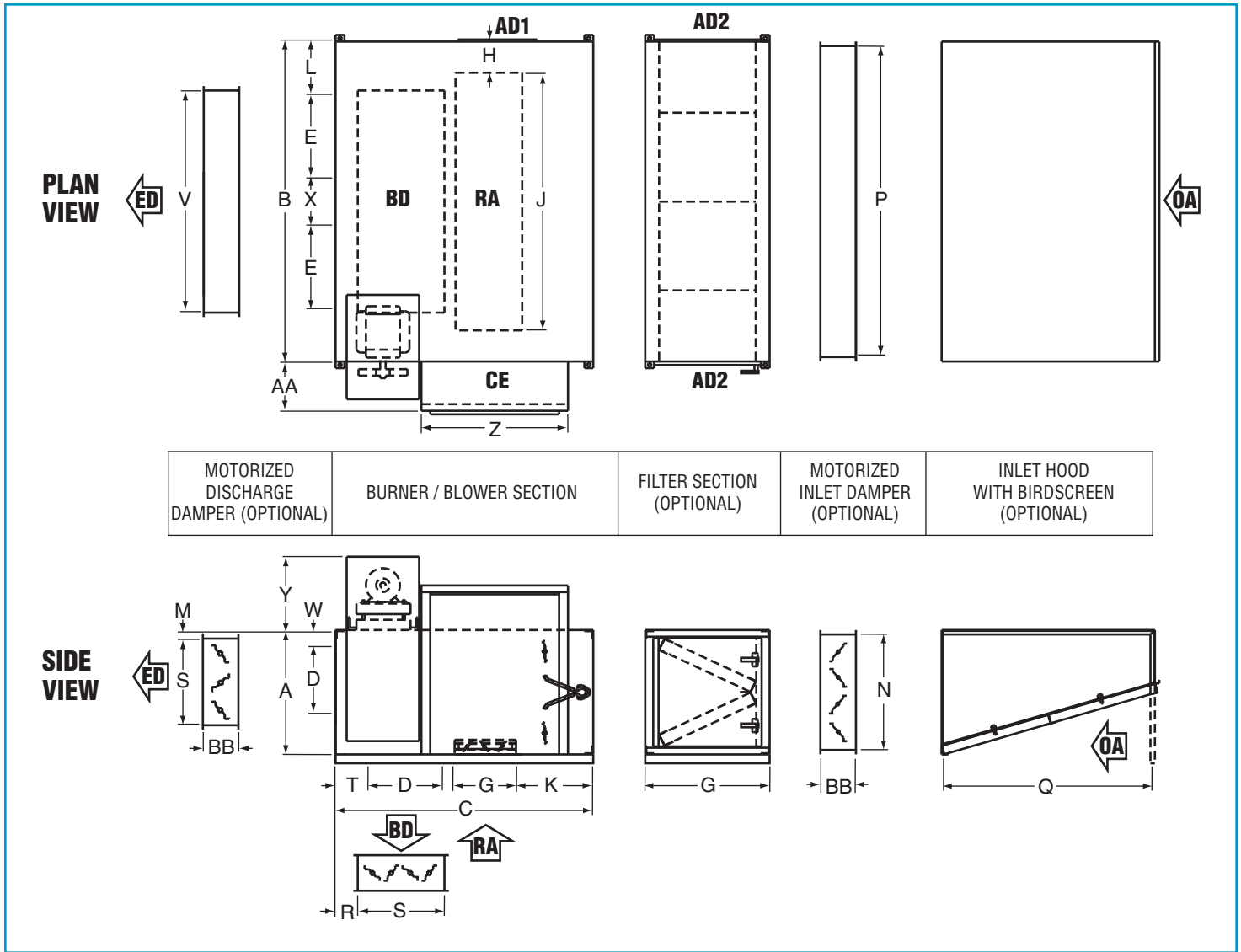

## CABINET DIMENSIONS

MODEL	A	B	C	D	E	F	G	H	J	K	L	M	N	P	Q	R	S	T	V	W	X	Y	Z	AA	BB
TT-212	28.0	60.0	58.0	13.4	15.6	24.0	15.0	5.0	50.0	16.0	8.9	1.0	26.0	58.0	48.0	5.0	19.5	7.0	50.0	1.0	11.0	18.5	33.0	16.9	8.0
TT-215	28.0	72.0	58.0	15.9	18.6	28.0	15.0	7.0	58.0	16.0	11.9	1.0	26.0	70.0	48.0	5.0	19.5	8.3	50.0	3.8	11.0	18.5	33.0	16.9	8.0
TT-218	36.0	72.0	62.0	18.9	21.9	24.0	15.0	7.0	58.0	14.0	7.0	6.0	33.0	69.0	72.0	6.0	26.0	10.5	58.0	10.5	14.3	20.0	33.0	16.9	8.0
TT-221	42.0	100.0	72.0	24.8	22.8	26.0	20.0	10.0	80.0	14.0	15.5	1.0	38.0	96.0	72.0	6.0	33.0	11.3	76.0	4.81	23.5	20.0	33.0	16.9	8.0

FILTERS*	
MODEL	FILTER SECTION
TT-212	9 - 2 x 20 x 20
TT-215	4 - 2 x 20 x 25 4 - 2 x 16 x 25
TT-218	8 - 2 x 20 x 20 8 - 2 x 16 x 20
TT-221	16 - 2 x 20 x 25

\*Permanent, Polyester or Pleated

LEGEND	
RA = Return Air	BD = Bottom Discharge
OA = Outside Air	ED = End Discharge
CE = Control Enclosure	AD2 = Filter Access Door
AD1 = Unit Access Door	TD = Top Discharge
SD = Side Discharge	

## IMPORTANT NOTES:

- All dimensions are in inches.
- All weights are in pounds.
- Shipping weights apply to both horizontal and upright models.
- All dimensions and weights are subject to change without notice.
- Some components may ship separately due to shipping constraints.
- Units only supplied with left-handed controls as shown.
- TT-212 through TT-221 inlet hoods must be supported.
- Dimensions for filter sections only apply to those sections using permanent, polyester or pleated filters. Contact Weather-Rite, LLC for dimensions of sections using bag or cartridge filters.

# TT-212 through TT-221 Upright Model Dimensions

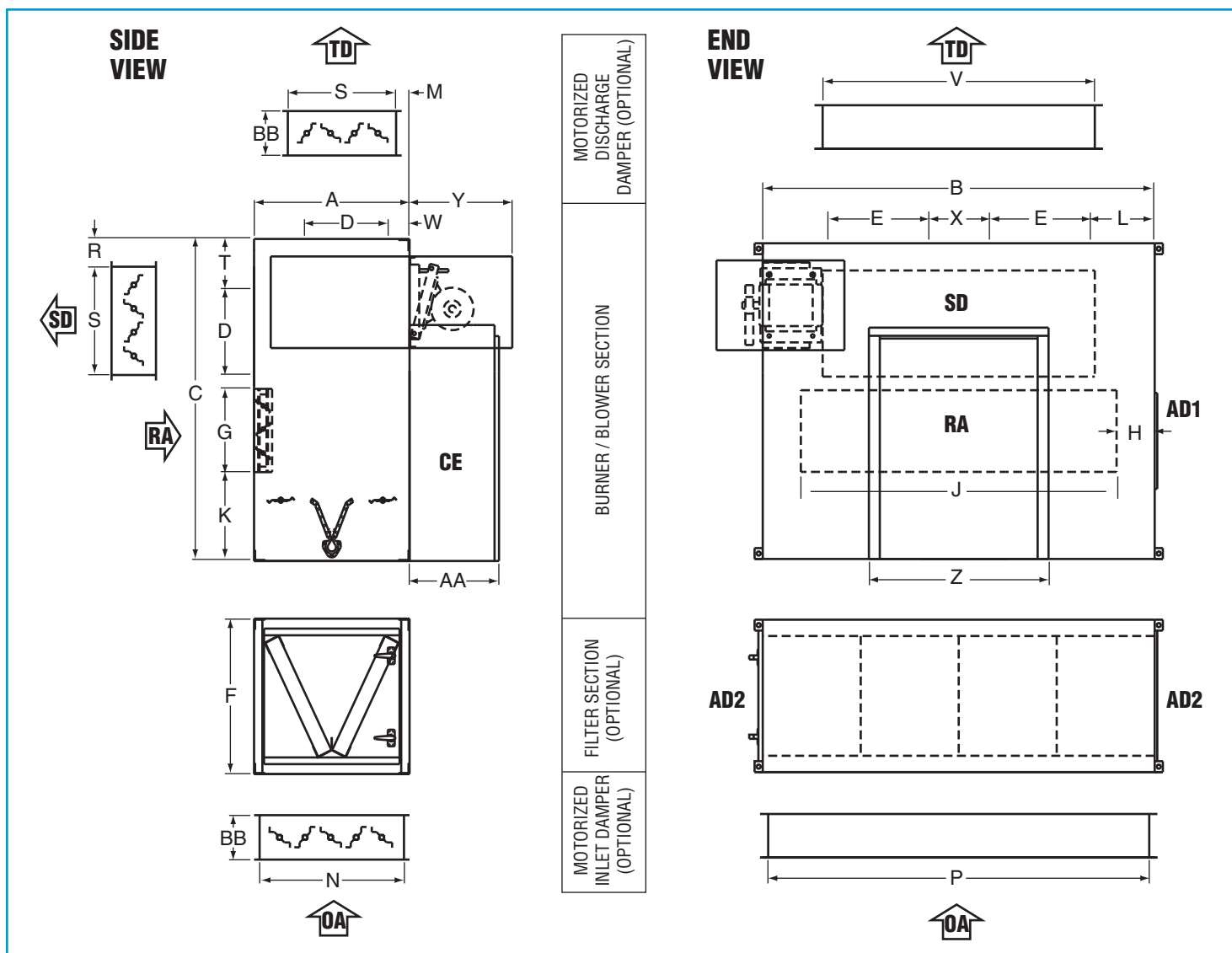

ESTIMATED SHIPPING WEIGHTS					
MODEL	BURNER / BLOWER SECTION	FILTER SECTION	INLET HOOD	WEATHERIZING	DISCHARGE OR INLET DAMPER
TT-212	560	95	45	75	70
TT-215	740	130	60	100	100
TT-218	950	300	150	135	150
TT-221	1,432	625	132	156	325

ESTIMATED SHIPPING WEIGHTS - MOTORS																
SIZE HP	.75	1	1.5	2	3	5	7.5	10	15	20	25	30	40	50	60	75
STD WEIGHT	35	35	45	45	70	85	130	155	220	275	300	360	500	550	800	950
2-SP WEIGHT	70	85	125	150	185	215	270	310	405	455	525	570	700	760	N/A	N/A

# TT-224 and TT-230 Horizontal Model Dimensions

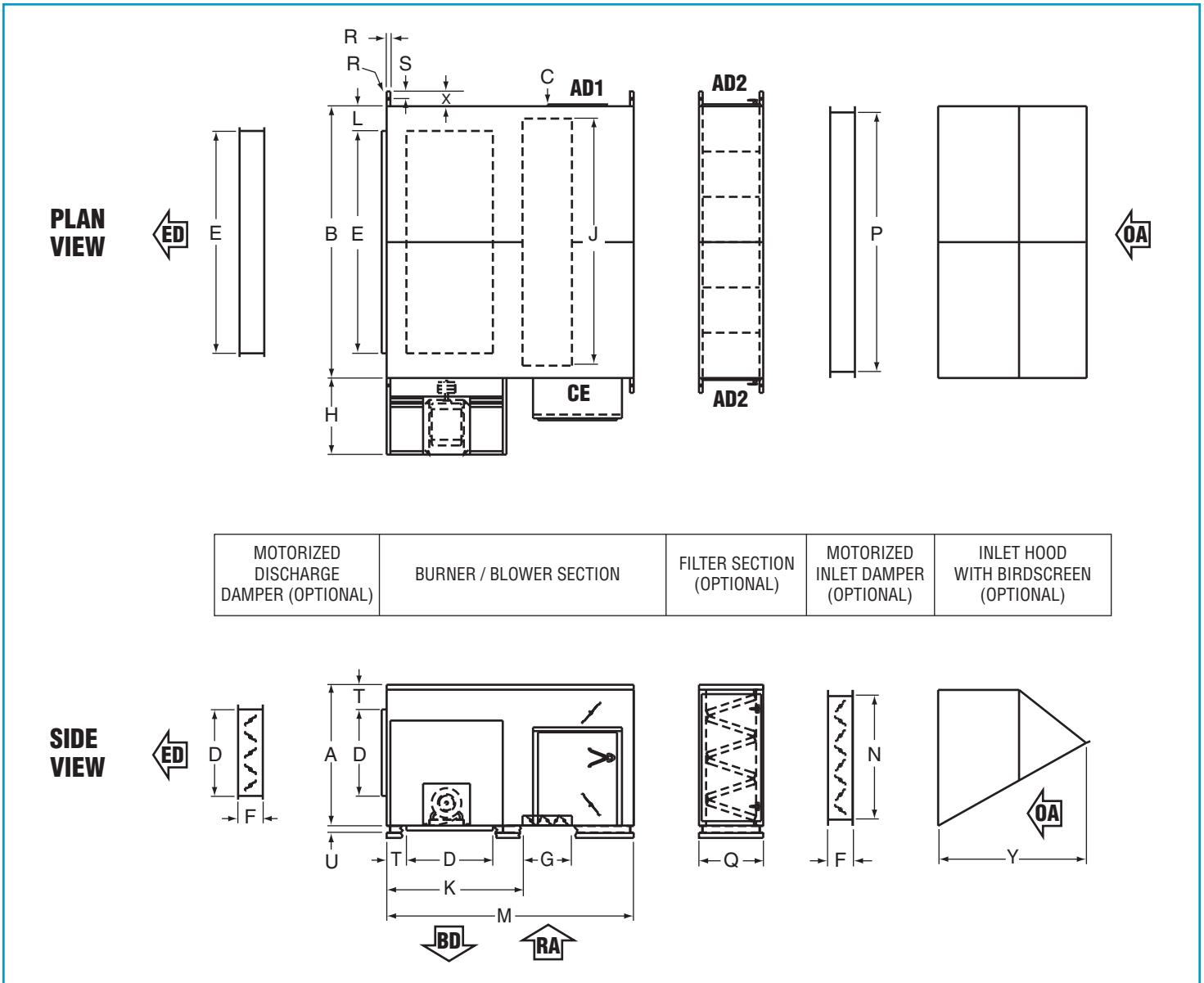

## CABINET DIMENSIONS

MODEL	A	B	C	D	E	F	G	H	J	K	L	M	N	P	Q	R	S	T	U	V	W	X	Y
TT-224	55.0	110.0	5.0	35.0	90.0	10.0	20.0	31.0	100.0	55.0	10.0	100.0	51	106.0	26.0	.75	3.0	8.0	3.0	116.0	122.0	6.0	60.0
TT-230	60.0	145.0	5.0	40.0	115.0	10.0	25.0	31.0	135.0	55.0	15.0	100.0	55	140.0	26.0	.75	3.0	5.0	4.0	151.0	157.0	6.0	60.0

FILTERS*	
MODEL	FILTER SECTION
TT-224	18 - 2 x 20 x 20
	12 - 2 x 20 x 25
TT-230	6 - 2 x 20 x 20
	30 - 2 x 20 x 25

\*Permanent, Polyester or Pleated

LEGEND	
<b>RA</b> = Return Air	<b>BD</b> = Bottom Discharge
<b>OA</b> = Outside Air	<b>ED</b> = End Discharge
<b>CE</b> = Control Enclosure	<b>AD2</b> = Filter Access Door
<b>AD1</b> = Unit Access Door	<b>TD</b> = Top Discharge
<b>SD</b> = Side Discharge	

## IMPORTANT NOTES:

- All dimensions are in inches.
- All weights are in pounds.
- Shipping weights apply to both horizontal and upright models.
- All dimensions and weights are subject to change without notice.
- Some components may ship separately due to shipping constraints.
- Units only supplied with left-handed controls as shown.
- Dimensions for filter sections only apply to those sections using permanent, polyester or pleated filters. Contact Weather-Rite, LLC for dimensions of sections using bag or cartridge filters.

# TT-224 and TT-230 Upright Model Dimensions

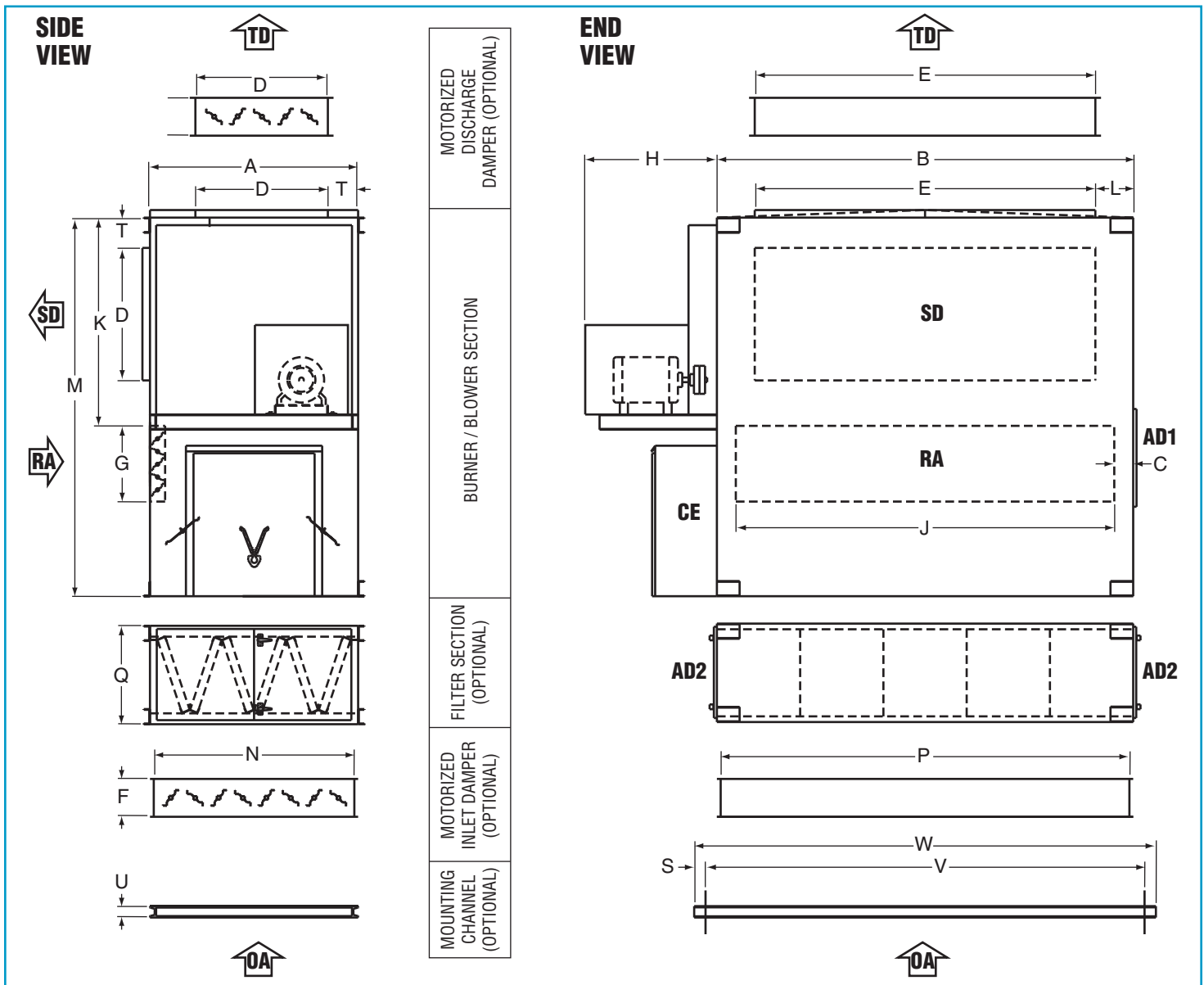

ESTIMATED SHIPPING WEIGHTS					
MODEL	BURNER / BLOWER SECTION	FILTER SECTION	INLET HOOD	WEATHERIZING	DISCHARGE OR INLET DAMPER
TT-224	2,975	980	182	200	470
TT-230	4,300	1,140	281	300	560

ESTIMATED SHIPPING WEIGHTS - MOTORS																
SIZE HP	.75	1	1.5	2	3	5	7.5	10	15	20	25	30	40	50	60	75
STD WEIGHT	35	35	45	45	70	85	130	155	220	275	300	360	500	550	800	950
2-SP WEIGHT	70	85	125	150	185	215	270	310	405	455	525	570	700	760	N/A	N/A

# TT-233 and TT-236 Non-Recirculating Horizontal Model Dimensions

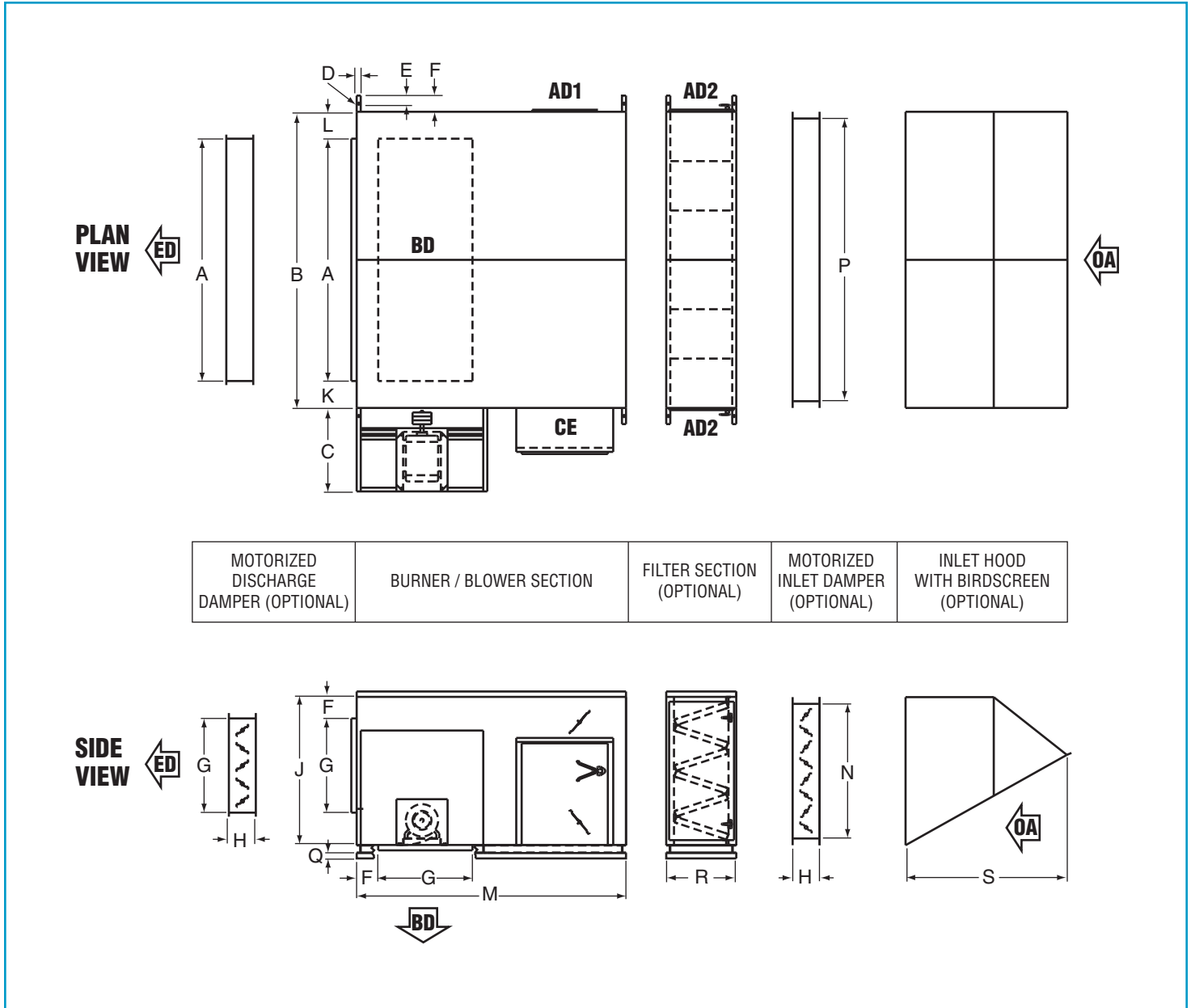

MOTORIZED DISCHARGE DAMPER (OPTIONAL)	BURNER / BLOWER SECTION	FILTER SECTION (OPTIONAL)	MOTORIZED INLET DAMPER (OPTIONAL)	INLET HOOD WITH BIRDSCREEN (OPTIONAL)
---------------------------------------	-------------------------	---------------------------	-----------------------------------	---------------------------------------

CABINET DIMENSIONS																			
MODEL	A	B	C	D	E	F	G	H	J	K	L	M	N	P	Q	R	S	V	W
TT-233	133.0	160.0	31.0	.8	3.0	6.0	43.0	10.0	72.0	17.0	10.0	110.0	67.0	155.0	4.0	26.0	60.0	166.0	172.0
TT-236	133.0	180.0	31.0	.8	3.0	6.0	43.0	10.0	72.0	22.0	25.0	110.0	67.0	175.0	4.0	26.0	60.0	186.0	192.0

FILTERS*	
MODEL	FILTER SECTION
TT-233	56 - 2 x 20 x 20
TT-236	63 - 2 x 20 x 20

\*Permanent, Polyester or Pleated

LEGEND	
RA = Return Air	BD = Bottom Discharge
OA = Outside Air	ED = End Discharge
CE = Control Enclosure	AD2 = Filter Access Door
AD1 = Unit Access Door	TD = Top Discharge
SD = Side Discharge	

## IMPORTANT NOTES:

- All dimensions are in inches.
- All weights are in pounds.
- Shipping weights apply to both horizontal and upright models.
- All dimensions and weights are subject to change without notice.
- Some components may ship separately due to shipping constraints.
- Units only supplied with left-handed controls as shown.
- Dimensions for filter sections only apply to those sections using permanent, polyester or pleated filters. Contact Weather-Rite, LLC for dimensions of sections using bag or cartridge filters.

# TT-233 and TT-236 Non-Recirculating Upright Model Dimensions

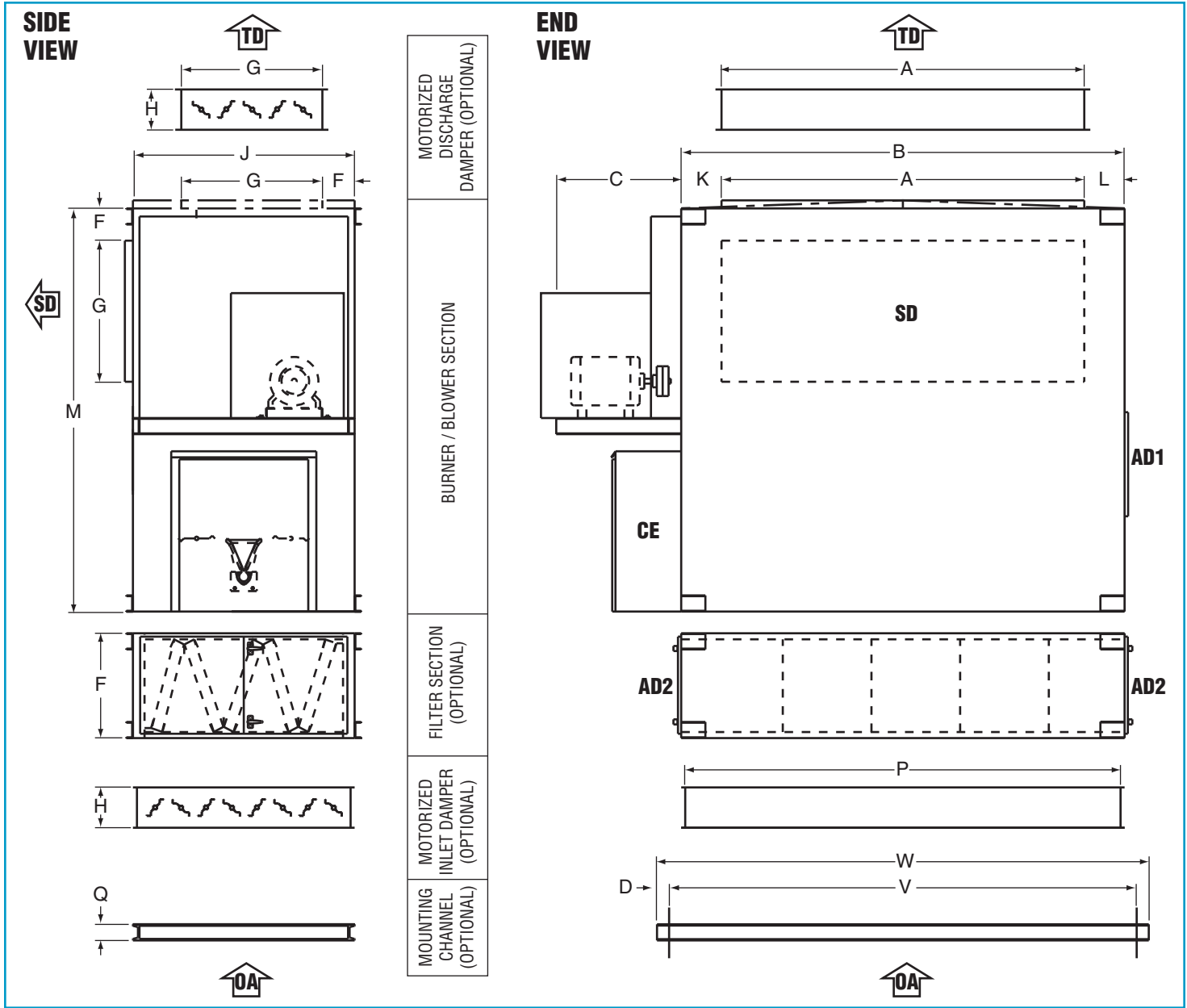

ESTIMATED SHIPPING WEIGHTS					
MODEL	BURNER / BLOWER SECTION	FILTER SECTION	INLET HOOD	WEATHERIZING	DISCHARGE OR INLET DAMPER
TT-233	5,600	1,300	365	325	690
TT-236	5,900	1,430	400	325	690

ESTIMATED SHIPPING WEIGHTS - MOTORS																
SIZE HP	.75	1	1.5	2	3	5	7.5	10	15	20	25	30	40	50	60	75
STD WEIGHT	35	35	45	45	70	85	130	155	220	275	300	360	500	550	800	950
2-SP WEIGHT	70	85	125	150	185	215	270	310	405	455	525	570	700	760	N/A	N/A

# TT-233 and TT-236 Recirculating Horizontal Model Dimensions

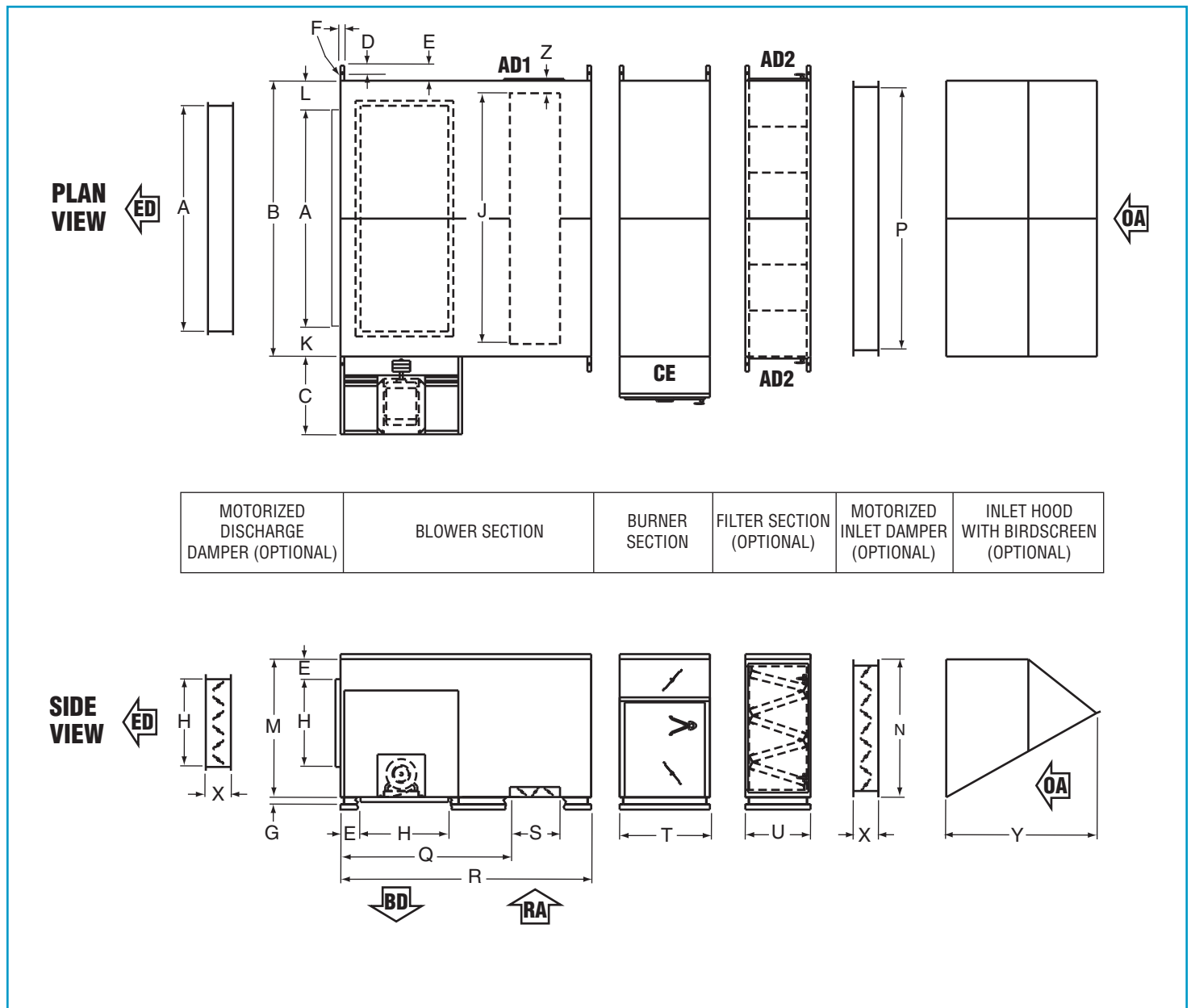

CABINET DIMENSIONS																								
MODEL	A	B	C	D	E	F	G	H	J	K	L	M	N	P	Q	R	S	T	U	V	W	X	Y	Z
TT-233	133.0	160.0	31.0	3.0	6.0	.8	4.0	43.0	150.0	17.0	10.0	72.0	67.0	155.0	75.0	110.0	25.0	36.0	26.0	166.0	172.0	10.0	60.0	5.0
TT-236	133.0	180.0	31.0	3.0	6.0	.8	4.0	43.0	170.0	22.0	25.0	72.0	67.0	175.0	75.0	110.0	25.0	36.0	26.0	186.0	192.0	10.0	60.0	5.0

FILTERS*	
MODEL	FILTER SECTION
TT-233	56 - 2 x 20 x 20
TT-236	63 - 2 x 20 x 20

\*Permanent, Polyester or Pleated

LEGEND	
RA = Return Air	BD = Bottom Discharge
OA = Outside Air	ED = End Discharge
CE = Control Enclosure	AD2 = Filter Access Door
AD1 = Unit Access Door	TD = Top Discharge
SD = Side Discharge	

## IMPORTANT NOTES:

- All dimensions are in inches.
- All weights are in pounds.
- Shipping weights apply to both horizontal and upright models.
- All dimensions and weights are subject to change without notice.
- Some components may ship separately due to shipping constraints.
- Units only supplied with left-handed controls as shown.
- Dimensions for filter sections only apply to those sections using permanent, polyester or pleated filters. Contact Weather-Rite, LLC for dimensions of sections using bag or cartridge filters.

# TT-233 and TT-236 Recirculating Upright Model Dimensions

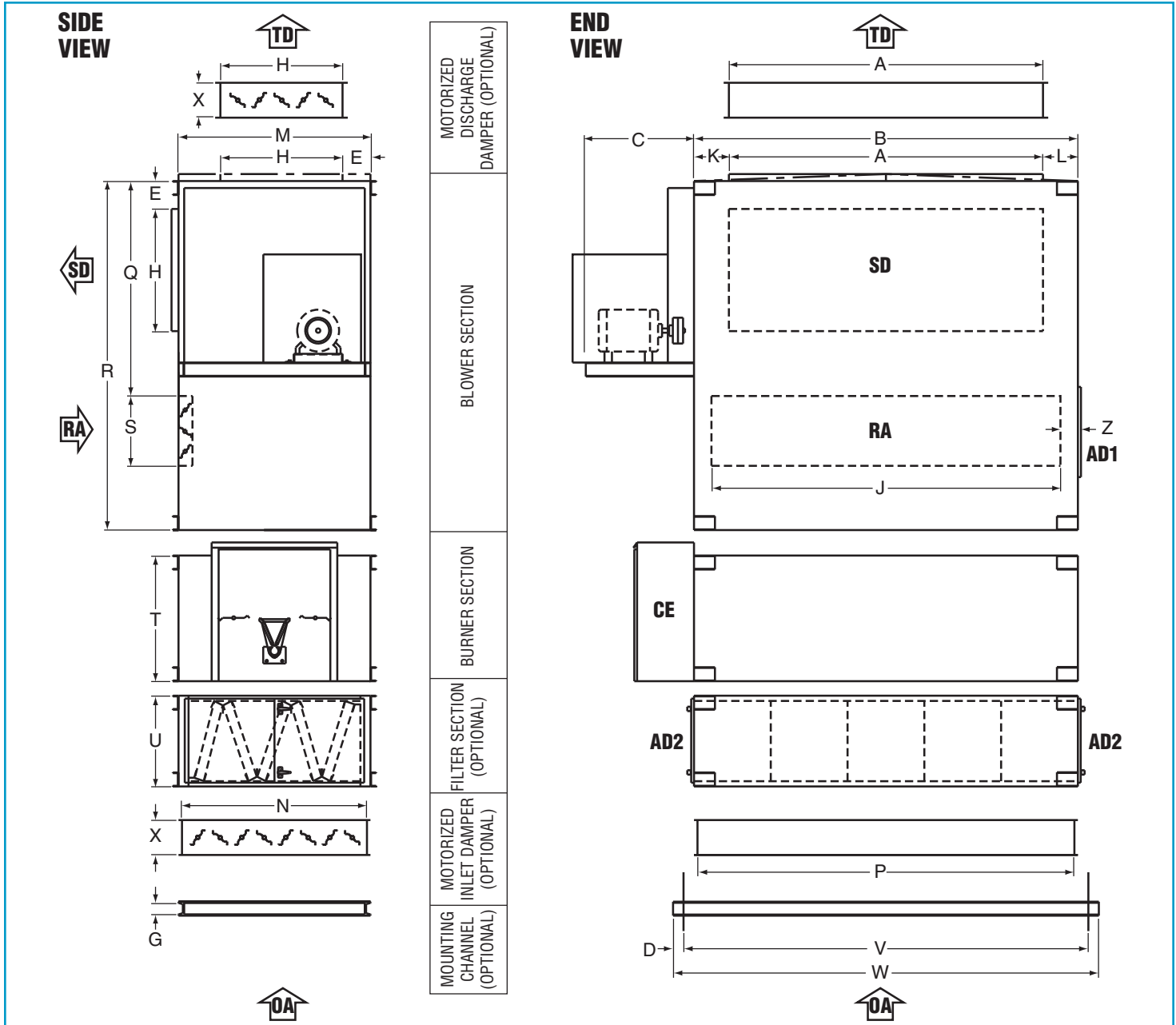

ESTIMATED SHIPPING WEIGHTS					
MODEL	BURNER / BLOWER SECTION	FILTER SECTION	INLET HOOD	WEATHERIZING	DISCHARGE OR INLET DAMPER
TT-233	5,600	1,300	365	325	690
TT-236	5,900	1,430	400	325	690

ESTIMATED SHIPPING WEIGHTS - MOTORS																
SIZE HP	.75	1	1.5	2	3	5	7.5	10	15	20	25	30	40	50	60	75
STD WEIGHT	35	35	45	45	70	85	130	155	220	275	300	360	500	550	800	950
2-SP WEIGHT	70	85	125	150	185	215	270	310	405	455	525	570	700	760	N/A	N/A

# TT-Series Roof Curbs

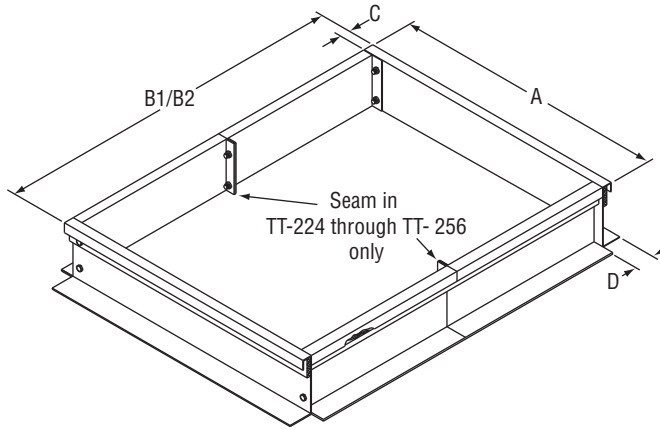

MODEL	WIDTH	LENGTH*	LENGTH*	DEPTH	BOTTOM FLANGE DEPTH	WEIGHT 1 *	WEIGHT 2 *
	A	B1	B2	C	D		
TT-112	35.2	57.2	81.2	1.9	3.0	75	98
TT-115	35.2	57.2	81.2	1.9	3.0	75	98
TT-118	59.2	89.2	89.2	1.9	3.0	N/A	100
TT-212	59.2	57.2	81.2	1.9	3.0	100	130
TT-215	71.2	57.2	85.2	1.9	3.0	125	163
TT-218	71.2	61.2	85.2	1.9	3.0	150	195
TT-221	99.2	71.2	97.2	1.9	3.0	200	260
TT-224	109.0	99.0	125.0	1.9	3.0	300	450
TT-230	144.0	99.0	125.0	1.9	3.0	375	488
TT-233	159.0	109.0	135.0	1.9	3.0	500	650
TT-236	179.0	109.0	135.0	1.9	3.0	500	650

\*The length indicated by dimension "B1" is for a roof curb designed to support the burner and blower sections. The weight for this type of roof curb is indicated by "Weight 1." The length indicated by dimension "B2" is for a roof curb designed to support the burner, blower and filter sections. The weight for this type of roof curb is indicated by "Weight 2."

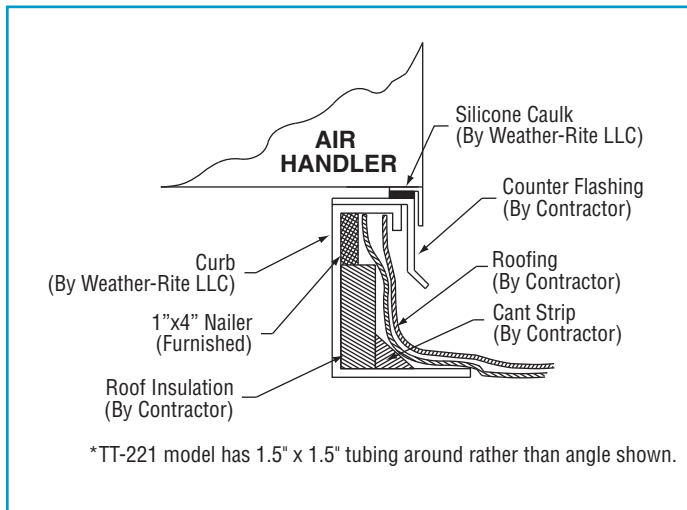

## IMPORTANT NOTES:

- All dimensions are in inches.
- All weights are in pounds.
- All dimensions and weights are subject to change without notice.
- Some components may ship separately due to shipping constraints.
- Curb is shipped broken down and must be field assembled (bolted together).
- The curb can be used with most conventional flat roofs. (e.g. bonded, corrugated etc.)
- When used with downblast TT-Series, the roof curb kit seals roof openings, preventing water leaks into the building.
- If other accessories extend beyond the curb, additional supports should be provided by the contractor and placed under the furthest section.
- Curbs are available in heights of 16" or 24".

# TT-Series Mounting Stand/Legs/Service Platform

## MOUNTING LEGS

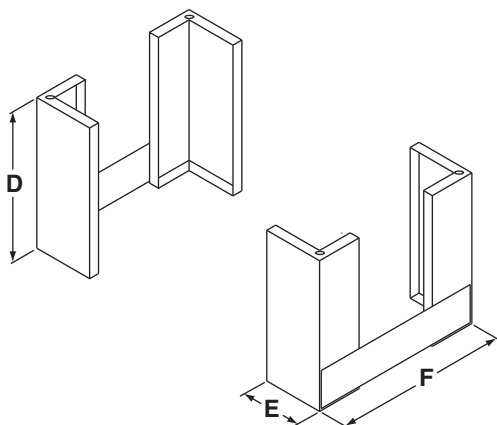

(Available on Upright TT112 through TT218 Models Only.)

## MOUNTING STAND

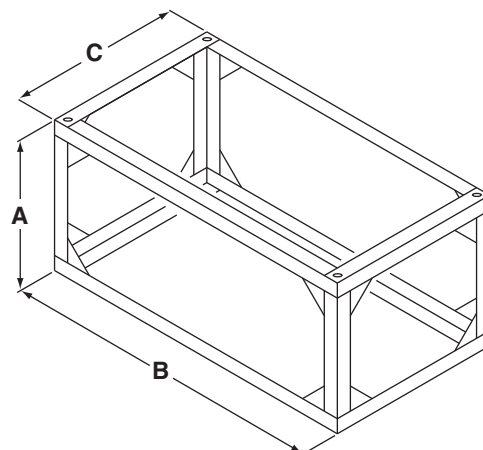

## SERVICE PLATFORM

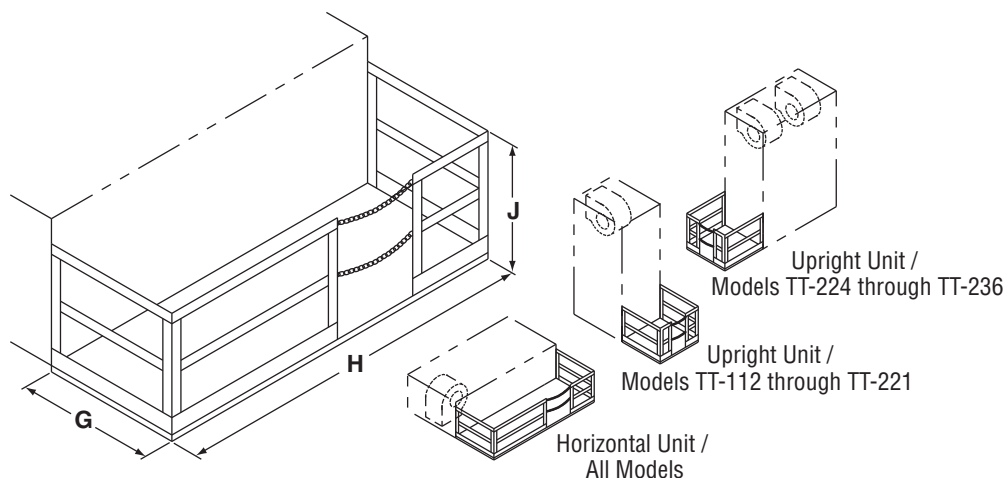

## IMPORTANT NOTES:

- All dimensions are in inches.
- All weights are in pounds.
- All dimensions and weights are subject to change without notice.
- Some components may ship separately due to shipping constraints.
- Service platform will be located on same side as control panel.
- Dimension "H" only applies to service platforms on upright units. For horizontal units, dimension "H" can be determined by adding the length of the unit's sections together.

MODEL	A	B	C	D	E	F	G	H	J	WEIGHTS		
										MOUNTING LEGS	MOUNTING STAND	SERVICE PLATFORM
TT-112	36	36	28	36	9.5	26	48	36	42	70	125	400
TT-115	36	36	28	36	9.5	26	48	36	42	70	125	400
TT-118	36	60	30	36	9.5	30	48	60	42	70	140	400
TT-212	36	60	28	36	9.5	26	48	60	42	70	140	400
TT-215	36	72	28	36	9.5	26	48	72	42	70	150	480
TT-218	36	72	36	36	9.5	33	48	72	42	70	160	480
TT-221	36	100	42	N/A	N/A	N/A	48	100	42	N/A	175	520
TT-224	46	110	55	N/A	N/A	N/A	72	55	42	N/A	300	575
TT-230	47	145	60	N/A	N/A	N/A	72	60	42	N/A	425	650
TT-233	55	160	72	N/A	N/A	N/A	72	72	42	N/A	700	700
TT-236	55	180	72	N/A	N/A	N/A	72	72	42	N/A	700	700

# TT-Series Discharge Accessories

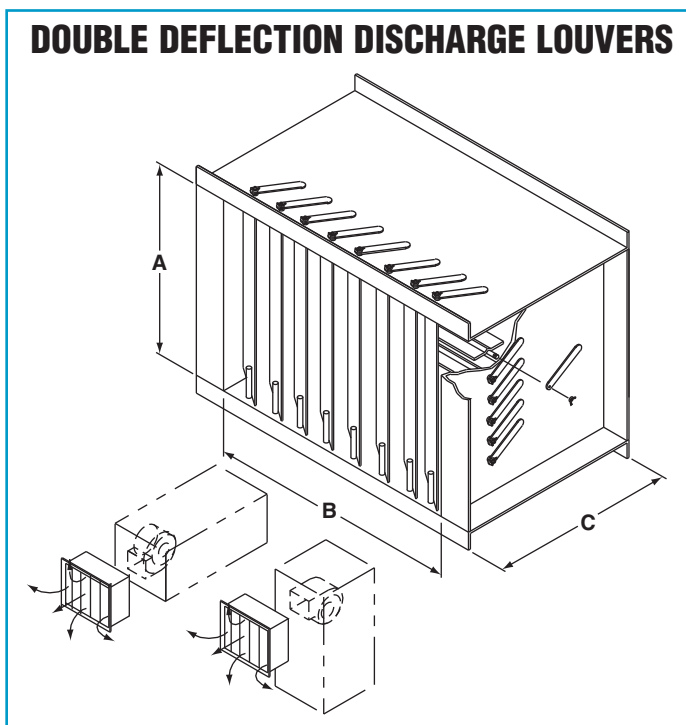
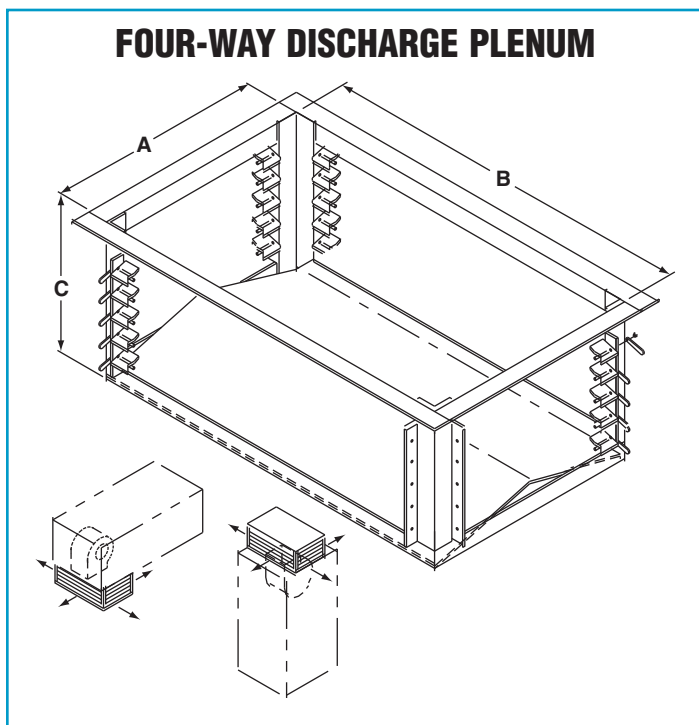

MODEL	A	B	C	WEIGHTS	
				FOUR-WAY DISCHARGE PLENUM	DOUBLE DEFLECTION DISCHARGE LOUVERS
TT-112	19.5	26	24	80	70
TT-115	19.5	26	24	80	70
TT-118	19.5	26	24	80	70
TT-212	19.5	50	24	80	70
TT-215	19.5	50	24	105	95
TT-218	26	58	24	140	130
TT-221	33	76	24	270	260
TT-224	35	90	24	385	375
TT-230	40	115	24	410	400
TT-233	43	133	24	510	500
TT-236	43	133	24	510	500

## IMPORTANT NOTES:

- All dimensions are in inches.
- All weights are in pounds.
- Shipping weights apply to both horizontal and upright models.
- All dimensions and weights are subject to change without notice.
- Some components may ship separately due to shipping constraints.

# TT-Series Selection Guide

**Step 1 - Model Identification:** Locate CFM requirement on Tables B - L. If several units can deliver the same air volume, the smaller unit should be selected, unless a significant savings in horsepower can be realized.

**Step 2 - Horsepower Requirements:** First, refer to the "Percentage of Capacity" (third column in Tables B-L) data provided for the unit chosen in Step 1. Locate this same percentage of capacity on the horizontal axis of Chart A. Draw a vertical line through that percentage, intersecting the curved lines of all the components. At the applicable intersection of points, go horizontally to the vertical axis and read the individual static pressures of each component.

Next, add all of the individual components plus the external static pressure (from the job requirement) together to determine the total static pressure. Add drive losses to this figure by multiplying total static pressure by a factor of 1.08.

Finally, return to the row of data (in Tables B-L) provided for the unit chosen in Step 1. Go horizontally across until under the total static pressure required. Read the brake horsepower (BHP) and select the next highest horsepower motor for the job.

**Step 3 - Burner or Electric Heating Coil Capacity:** To compute necessary output of direct-fired burner, use the following formulas:

$$\text{Btu/h output required} = \text{CFM} \times 1.08 \times \text{temperature rise}$$

$$\text{MBH} = \text{Btu/h} / 1000$$

To compute the necessary output of electrical heating coil, use the following formulas:

$$\text{Btu/h output required} = \text{CFM} \times 1.08 \times \text{temperature rise}$$

$$1 \text{ kW} = 3,412 \text{ Btu/h}$$

**Step 4 - Gas Train Size:** To compute necessary gas train size, locate the required burner capacity level in Table A. Choose the appropriate gas train size based on project's inlet gas pressure. For gas pressures above those listed in Table A, a high gas pressure regulator is required.

**Chart A: Internal Static Pressures (ISP)**

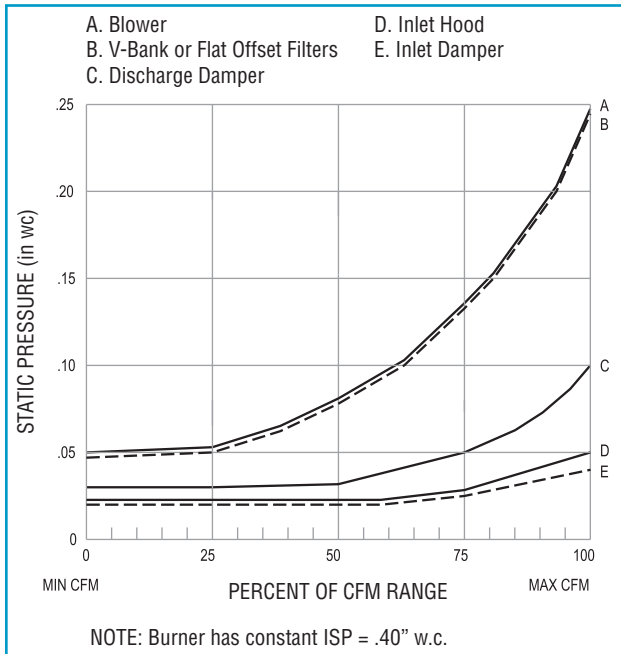

**Table A: Gas Train Selection**

BURNER CAPACITY	GAS PRESSURE	GAS TRAIN DIAMETER
Under 1,000 MBH	7" w.c. - 11" w.c.	1"
	12" w.c. - 1PSI	1"
1,000 - 1,650 MBH	7" w.c. - 11" w.c.	1.25"
	12" w.c. - 5PSI	1"
1,651 - 2,499 MBH	7" w.c. - 11" w.c.	1.5"
	12" w.c. - 5PSI	1.25"
2,500 - 3,000 MBH	7" w.c. - 11" w.c.	2"
	12" w.c. - 5PSI	1.5"
3,001 - 4,000 MBH	7" w.c. - 11" w.c.	2.5"
	12" w.c. - 5PSI	2"
4,001 - 5,000 MBH	8" w.c. - 11" w.c.	3"
	12" w.c. - 20" w.c.	2.5"
	21" w.c. - 5PSI	2"
5,001 - 6,000 MBH	11" w.c. - 20" w.c.	3"
	21" w.c. - 5PSI	2.5"
6,001 - 8,000 MBH	12" w.c. - 5PSI	3"
8,001 - 9,000 MBH	12" w.c. - 5PSI	3"

**Tables B - L: Blower Motor Horsepower Selection**

TT-112	TOTAL S.P.		PERCENTAGE OF CAPACITY	.50		0.75		1.00		1.25		1.50		1.75		2.00		2.25		2.50	
	CFM	O.V.		RPM	BHP	RPM	BHP	RPM	BHP	RPM	BHP	RPM	BHP	RPM	BHP	RPM	BHP	RPM	BHP	RPM	BHP
	1,600	1,111	0	603	0.23																
1,800	1,250	20	609	0.27	737	0.38															
2,000	1,388	30	617	0.33	741	0.43	850	0.55													
2,200	1,527	40	627	0.38	746	0.50	852	0.62	951	0.76											
2,400	1,666	50	641	0.44	754	0.57	858	0.71	953	0.84	1041	0.99									
2,600	1,805	60	656	0.52	764	0.65	864	0.80	956	0.94	1043	1.10	1125	1.24							
2,800	1,944	70	673	0.60	775	0.75	872	0.90	962	1.06	1047	1.21	1127	1.37	1203	1.54					
3,200	2,222	80	712	0.80	805	0.96	894	1.13	970	1.17	1058	1.48	1135	1.66	1208	1.83	1278	2.03	1345	2.22	
3,600	2,500	90	759	1.06	841	1.22	922	1.40	1001	1.59	1077	1.78	1149	1.98	1219	2.18	1286	2.38	1350	2.58	
4,000	2,777	100	808	1.37	881	1.54	956	1.73	1029	1.94	1100	2.14	1169	2.36	1235	2.57	1300	2.80	1362	3.00	

# Tables B - L: Blower Motor Horsepower Selection (cont.)

TT-115	TOTAL S.P.		PERCENTAGE OF CAPACITY	.50		0.75		1.00		1.25		1.50		1.75		2.00		2.25		2.50	
	CFM	O.V.		RPM	BHP	RPM	BHP	RPM	BHP	RPM	BHP	RPM	BHP	RPM	BHP	RPM	BHP	RPM	BHP	RPM	BHP
	2,250	1,119	20	497	0.31																
2,500	1,243	30	501	0.36	608	0.50															
3,000	1,492	40	513	0.47	613	0.63	702	0.81													
3,500	1,741	50	528	0.62	623	0.81	708	0.99	786	1.19	860	1.40									
4,000	1,990	60	548	0.82	637	1.00	720	1.22	793	1.43	863	1.66	928	1.89	993	2.14					
4,500	2,238	70	574	1.07	654	1.27	732	1.49	805	1.73	872	1.96	935	2.22	995	2.47	1053	2.73	1110	3.00	
5,000	2,487	80	607	1.37	675	1.57	748	1.80	819	2.00	884	2.32	945	2.58	1003	2.86	1058	3.13	1112	3.42	
5,500	2,736	90	645	1.74	703	1.94	767	2.18	833	2.45	897	2.73	957	3.00	1014	3.30	1068	3.60	1119	3.90	
6,000	2,985	100	686	2.18	734	2.38	791	2.62	851	2.90	913	3.20	971	3.50	1027	3.81	1079	4.13	1130	4.44	

TT-118	TOTAL S.P.		PERCENTAGE OF CAPACITY	.50		0.75		1.00		1.25		1.50		1.75		2.00		2.25		2.50	
	CFM	O.V.		RPM	BHP	RPM	BHP	RPM	BHP	RPM	BHP	RPM	BHP	RPM	BHP	RPM	BHP	RPM	BHP	RPM	BHP
	5,000	1,742	0	463	0.99	544	1.28	617	1.57	685	1.87	746	2.17	803	2.49						
5,500	1,916	10	476	1.18	554	1.50	625	1.81	690	2.14	750	2.47	806	2.81	860	3.15	910	3.50			
6,000	2,090	20	490	1.41	564	1.75	633	2.09	696	2.44	755	2.80	810	3.15	862	3.52	913	3.89	960	4.27	
6,500	2,264	30	504	1.67	576	2.04	642	2.41	704	2.77	762	3.15	816	3.53	867	3.92	917	4.33	963	4.73	
7,000	2,439	40	521	1.96	590	2.35	653	2.74	713	3.14	769	3.54	823	3.96	872	4.37	921	4.79	967	5.21	
7,500	2,613	50	538	2.29	603	2.71	666	3.12	724	3.54	779	3.98	830	4.41	880	4.85	926	5.29	972	5.74	
8,000	2,787	60	557	2.66	619	3.10	678	3.54	735	4.00	788	4.45	839	4.91	887	5.37	934	5.83	978	6.31	
8,500	2,961	70	576	3.08	636	3.53	693	4.01	747	4.48	799	4.96	848	5.44	896	5.93	941	6.42	985	6.92	
9,000	3,135	80	596	3.53	653	4.02	708	4.52	761	5.00	810	5.52	859	6.03	905	6.54	950	7.06	993	7.50	
9,500	3,310	90	616	4.04	671	4.55	724	5.00	774	5.60	823	6.13	870	6.67	916	7.21	959	7.74	1001	8.29	
10,000	3,484	100	638	4.60	690	5.14	741	5.68	789	6.22	837	6.78	883	7.34	926	7.91	970	8.47	1011	9.04	

TT-212	TOTAL S.P.		PERCENTAGE OF CAPACITY	.50		0.75		1.00		1.25		1.50		1.75		2.00		2.25		2.50	
	CFM	O.V.		RPM	BHP	RPM	BHP	RPM	BHP	RPM	BHP	RPM	BHP	RPM	BHP	RPM	BHP	RPM	BHP	RPM	BHP
	3,600	1,250	20	609	0.55																
4,000	1,388	30	617	0.64	741	0.87															
4,400	1,527	40	627	0.76	746	1.00	852	1.24													
4,800	1,666	50	641	0.87	754	1.15	858	1.41	953	1.69											
5,200	1,805	60	656	1.03	763	1.31	864	1.59	956	1.89											
5,600	1,944	70	673	1.20	775	1.49	872	1.79	962	2.10	1047	2.42									
6,400	2,222	80	712	1.60	805	1.92	894	2.25	978	2.60	1058	2.95	1135	3.31	1208	3.67					
7,200	2,500	90	759	2.11	841	2.45	922	2.81	1001	3.19	1077	3.57	1149	3.97	1219	4.37	1286	4.77	1350	5.18	
8,000	2,777	100	808	2.74	881	3.09	956	3.47	1029	3.87	1100	4.29	1169	4.72	1235	5.45	1300	5.59	1362	6.05	

TT-215	TOTAL S.P.		PERCENTAGE OF CAPACITY	.50		0.75		1.00		1.25		1.50		1.75		2.00		2.25		2.50	
	CFM	O.V.		RPM	BHP	RPM	BHP	RPM	BHP	RPM	BHP	RPM	BHP	RPM	BHP	RPM	BHP	RPM	BHP	RPM	BHP
	5,000	1,244	0	501	0.72																
6,000	1,492	15	513	0.95	613	1.28															
7,000	1,741	30	528	1.26	624	1.61	708	1.99													
8,000	1,990	40	548	1.64	637	2.03	720	2.45	793	2.87	863	3.32									
9,000	2,238	55	574	2.12	654	2.53	732	2.98	805	3.45	872	3.94	935	4.42	995	4.94					
10,000	2,487	70	607	2.73	675	3.14	748	3.61	819	4.13	884	4.64	945	5.17	1003	5.72	1058	6.27	1112	6.84	
11,000	2,736	85	645	3.47	703	3.88	767	4.37	833	4.90	897	5.45	957	6.02	1014	6.60	1068	7.20	1119	7.80	
12,000	2,985	100	686	4.37	734	4.78	791	5.25	851	5.80	913	6.38	971	6.99	1027	7.62	1079	8.25	1130	8.89	

# Tables B - L: Blower Motor Horsepower Selection (cont.)

TT-218	TOTAL S.P.		PERCENTAGE OF CAPACITY	.50		0.75		1.00		1.25		1.50		1.75		2.00		2.25		2.50	
	CFM	O.V.		RPM	BHP	RPM	BHP	RPM	BHP	RPM	BHP	RPM	BHP	RPM	BHP	RPM	BHP	RPM	BHP	RPM	BHP
	9,000	1,071	0	453	1.64	537	2.16	612	2.69												
10,000	1,745	10	463	1.97	544	2.55	617	3.13	685	3.73											
11,000	1,920	20	476	2.37	554	3.00	625	3.63	690	4.27	750	4.94									
12,000	2,094	30	489	2.83	564	3.50	633	4.19	696	4.88	755	5.59	810	6.31	863	7.04					
13,000	2,269	40	504	3.34	576	4.06	642	4.80	704	5.55	762	6.31	816	7.07	867	7.85	917	8.64			
14,000	2,443	50	521	3.92	590	4.71	653	5.49	713	6.29	769	7.09	823	7.91	872	8.74	921	9.57	970	10.42	
15,000	2,618	60	538	4.59	603	5.41	666	6.26	724	7.10	779	7.95	830	8.82	880	9.70	926	10.55	973	11.39	
16,000	2,792	70	557	5.33	619	6.20	678	7.09	735	7.99	788	8.90	839	9.81	887	10.66	934	11.61	975	12.55	
17,000	2,967	80	576	6.15	636	7.08	693	8.02	747	8.97	799	9.93	848	10.87	896	11.82	941	12.77	985	13.82	
18,000	3,141	90	596	7.07	653	8.04	708	9.03	761	10.03	810	10.97	859	12.03	905	13.08	950	14.03	993	15.16	
20,000	3,490	100	638	9.19	690	10.27	741	11.29	789	12.45	837	13.50	883	14.66	926	15.72	970	16.88	1011	18.04	

TT-221	TOTAL S.P.		PERCENTAGE OF CAPACITY	.50		0.75		1.00		1.25		1.50		1.75		2.00		2.25		2.50	
	CFM	O.V.		RPM	BHP	RPM	BHP	RPM	BHP	RPM	BHP	RPM	BHP	RPM	BHP	RPM	BHP	RPM	BHP	RPM	BHP
	10,000	1,278	0	382	1.53	458	2.06														
12,000	1,534	10	397	2.11	466	2.72	531	3.35													
14,000	1,790	20	415	2.85	480	3.54	540	4.26	595	4.99	648	5.75									
16,000	2,046	30	436	3.77	497	4.56	554	5.36	606	6.17	655	7.01	703	7.85	748	8.72					
18,000	2,301	40	460	4.91	516	5.78	570	6.67	619	7.57	667	8.49	711	9.41	754	10.35	795	11.29	837	12.23	
20,000	2,557	50	487	6.30	538	7.24	589	8.22	636	9.21	682	10.22	724	11.18	765	12.24	805	13.19	843	14.24	
22,000	2,813	60	517	7.97	563	8.98	610	10.03	654	11.08	697	12.13	739	13.29	779	14.35	817	15.51	853	16.67	
24,000	3,069	70	548	9.94	590	10.97	633	12.13	675	13.29	716	14.45	755	15.61	793	16.88	830	18.04	866	19.31	
26,000	3,324	80			619	13.29	658	14.56	697	15.72	736	16.99	774	18.36	810	19.62	846	20.89	881	22.26	
28,000	3,580	90					686	17.30	722	18.67	759	19.94	794	21.31	829	22.68	864	24.16	897	25.53	
30,000	3,836	100					714	20.57	749	21.94	783	23.32	817	24.79	850	26.16	883	27.64	915	29.22	

TT-224	TOTAL S.P.		PERCENTAGE OF CAPACITY	.50		0.75		1.00		1.25		1.50		1.75		2.00		2.25		2.50	
	CFM	O.V.		RPM	BHP	RPM	BHP	RPM	BHP	RPM	BHP	RPM	BHP	RPM	BHP	RPM	BHP	RPM	BHP	RPM	BHP
	25,000	1,862	0	327	4.94	376	6.16	420	7.46	463	8.84	503	10.32								
27,000	2,011	10	338	5.79	384	7.09	426	8.45	467	9.89	506	11.39	544	12.98	580	14.66					
29,000	2,160	20	348	6.75	392	8.13	434	9.56	473	10.97	511	12.55	546	14.24	581	15.93	616	17.72			
31,000	2,309	30	359	7.83	402	9.31	442	10.76	480	12.34	516	13.93	551	15.61	584	17.41	617	19.20	650	21.10	
33,000	2,459	40	370	9.03	413	10.55	452	12.13	487	13.72	522	15.40	556	17.20	588	18.99	620	20.89	651	22.79	
35,000	2,608	50			423	11.92	461	13.61	496	15.30	530	17.09	593	18.88	593	20.68	624	22.68	654	24.58	
37,000	2,757	60			435	13.50	471	15.30	505	17.09	538	18.88	599	20.68	599	22.58	629	24.58	658	26.59	
39,000	2,906	70					481	17.09	515	18.99	546	20.78	606	22.79	606	24.69	635	26.69	663	28.80	
41,000	3,055	80					492	19.10	524	20.99	555	23.00	614	24.90	614	27.01	641	29.01	669	31.23	
43,000	3,204	90							535	23.21	565	25.21	622	27.32	622	29.43	649	31.54	675	33.76	
45,000	3,353	100							545	25.64	575	27.75	631	29.86	631	32.07	657	34.29	683	36.50	

TT-230	TOTAL S.P.		PERCENTAGE OF CAPACITY	.50		0.75		1.00		1.25		1.50		1.75		2.00		2.25		2.50	
	CFM	O.V.		RPM	BHP	RPM	BHP	RPM	BHP	RPM	BHP	RPM	BHP	RPM	BHP	RPM	BHP	RPM	BHP	RPM	BHP
	30,000	1,612	0	252	4.86	298	6.35	339	8.00												
33,000	1,774	10	260	5.82	302	7.40	341	9.09	379	10.87											
36,000	1,935	20	267	6.93	307	8.61	345	10.38	381	12.24	415	14.24									
39,000	2,096	30	276	8.20	314	9.98	350	11.82	384	13.72	417	15.83	448	18.04							
42,000	2,258	40	285	9.62	322	11.50	357	13.40	388	15.51	420	17.62	450	19.94	479	22.26	507	24.79			
45,000	2,419	50			330	13.19	363	15.30	395	17.48	424	19.62	453	21.94	481	24.37	509	29.60	536	29.64	
48,000	2,580	60			339	15.19	370	17.41	401	19.62	429	21.94	457	24.27	484	26.80	511	29.33	537	32.07	
51,000	2,741	70					379	19.62	407	21.94	436	24.41	462	26.80	488	29.43	514	32.07	539	34.82	
54,000	2,903	80					387	22.16	415	24.58	442	27.11	468	29.69	493	32.28	518	35.03	542	37.77	
57,000	3,064	90							423	27.43	449	30.07	475	32.71	499	35.47	522	38.19	545	41.04	
60,000	3,225	100							431	30.49	457	33.23	481	36.08	505	38.82	529	41.76	550	44.63	

# Tables B - L: Blower Motor Horsepower Selection (cont.)

TT-233	TOTAL S.P.		PERCENTAGE OF CAPACITY	.50		0.75		1.00		1.25		1.50		1.75		2.00		2.25		2.50	
	CFM	O.V.		RPM	BHP	RPM	BHP	RPM	BHP	RPM	BHP	RPM	BHP	RPM	BHP	RPM	BHP	RPM	BHP	RPM	BHP
	40,000	1,659	0	239	7.36	276	9.20	312	11.15												
	43,000	1,784	8	246	8.53	282	10.50	315	12.45	347	14.66										
	46,000	1,908	16	252	9.84	287	11.92	320	14.03	350	16.29	380	20.36								
	49,000	2,033	25	258	11.29	293	13.50	324	15.72	353	18.07	382	20.50								
	52,000	2,157	33			300	15.19	329	17.62	358	19.94	385	22.47	411	25.14						
	55,000	2,282	41			306	17.09	335	19.62	363	22.16	389	24.77	415	27.44	440	30.23				
	58,000	2,406	50			342	21.83	342	21.84	368	24.48	394	27.11	419	29.95	442	32.80	466	35.76		
	61,000	2,531	58					348	24.27	373	27.01	399	29.85	423	32.60	446	35.55	468	38.62	492	41.67
	64,000	2,655	66					354	26.80	380	29.79	404	32.71	427	35.55	450	38.64	473	41.67	494	44.91
	67,000	2,780	75					361	29.65	386	32.71	410	35.76	433	38.82	455	41.88	476	45.05	497	48.32
	70,000	2,904	83							392	35.76	416	39.05	438	42.20	460	45.37	481	48.68	501	51.91
	73,000	3,029	91							400	39.21	422	42.52	444	45.79	465	49.17	485	52.43	505	55.92
	7,5000	3,112	100									426	44.94	448	48.32	468	51.81	488	55.18	509	67.20

TT-236	TOTAL S.P.		PERCENTAGE OF CAPACITY	.50		0.75		1.00		1.25		1.50		1.75		2.00		2.25		2.50	
	CFM	O.V.		RPM	BHP	RPM	BHP	RPM	BHP	RPM	BHP	RPM	BHP	RPM	BHP	RPM	BHP	RPM	BHP	RPM	BHP
	50,000	1,953	0	244	10.76	274	12.98	303	11.15	330	17.51	358	20.02								
	53,000	2,070	8	250	12.24	281	14.66	308	12.45	334	19.38	360	21.89	385	24.55						
	56,000	2,187	16	256	13.93	287	16.35	313	14.03	339	21.31	364	23.96	387	26.65						
	59,000	2,304	25			293	18.36	320	15.72	344	23.55	368	26.16	391	28.97	414	31.83				
	62,000	2,421	33			299	20.41	326	17.62	349	25.85	372	28.65	394	31.48	417	34.41	438	37.46		
	65,000	2,539	41					332	19.62	356	28.44	378	31.23	399	34.18	420	37.14	441	40.30	462	43.53
	68,000	2,656	50					339	21.84	362	31.12	383	34.08	404	37.14	424	40.22	444	43.36	464	46.63
	71,000	2,773	58					345	24.27	367	34.08	389	37.14	409	40.29	429	43.46	448	46.63	468	50.02
	74,000	2,890	66					351	33.87	373	37.14	395	40.42	415	43.57	435	46.84	454	50.24	472	53.59
	77,000	3,007	75							381	40.41	401	43.78	421	47.16	440	50.60	458	54.02	476	57.49
	80,000	3,124	83							387	43.89	407	47.48	426	50.96	445	54.51	463	58.04	481	61.51
	83,000	3,242	91							394	47.69	414	51.38	433	54.97	452	58.67	468	62.30	486	65.94
	85,000	3,320	100							398	50.29	418	54.02	437	57.85	455	61.50	473	65.20	490	69.01

## Installation Code and Annual Inspections:

All installations and service of WEATHER-RITE™ equipment must be performed by a contractor qualified in the installation and service of equipment sold and supplied by Weather-Rite LLC and conform to all requirements set forth in the WEATHER-RITE™ manuals and all applicable governmental authorities pertaining to the installation, service and operation of the equipment. To help facilitate optimum performance and safety, Weather-Rite LLC recommends that a qualified contractor annually inspect your WEATHER-RITE™ equipment and perform service where necessary, using only replacement parts sold and supplied by Weather-Rite LLC.

**Further Information:** Applications, engineering and detailed guidance on systems design, installation and equipment performance is available through WEATHER-RITE™ representatives. Please contact us for any further information you may require, including the Installation, Operation and Service Manual.

**This product is not for residential use.**

**This document is intended to assist licensed professionals in the exercise of their professional judgement.**

## Weather-Rite LLC

616 North 5th Street  
 Minneapolis, MN 55401  
 Telephone: 612.338.1401  
 Fax: 612.338.6783  
 Toll Free: 1.800.589.3691

[www.weather-rite.com](http://www.weather-rite.com)

© 2008 Weather-Rite LLC All rights reserved. No part of this work covered by the copyrights herein may be reproduced or copied in any form or by any means – graphic, electronic, or mechanical, including photocopying, recording, taping, or information storage and retrieval systems without written permission of Weather-Rite LLC.