

## ***IDF-Series***

# ***Indirect-Fired Heating, Cooling and Ventilation Systems***

- Discharge air free of combustion by-products.
- High efficiency due to three or four pass heat exchanger design.
- Longer part longevity: Motors, belts and bearings are placed out of the airstream.
- Rugged, heavy-duty construction: Unit cabinet is supported by welded steel frame. Casing is finish-coated to help protect against corrosion.
- Modular design allows for custom configurations to meet customers' needs.
- Evaporative and mechanical cooling packages available.

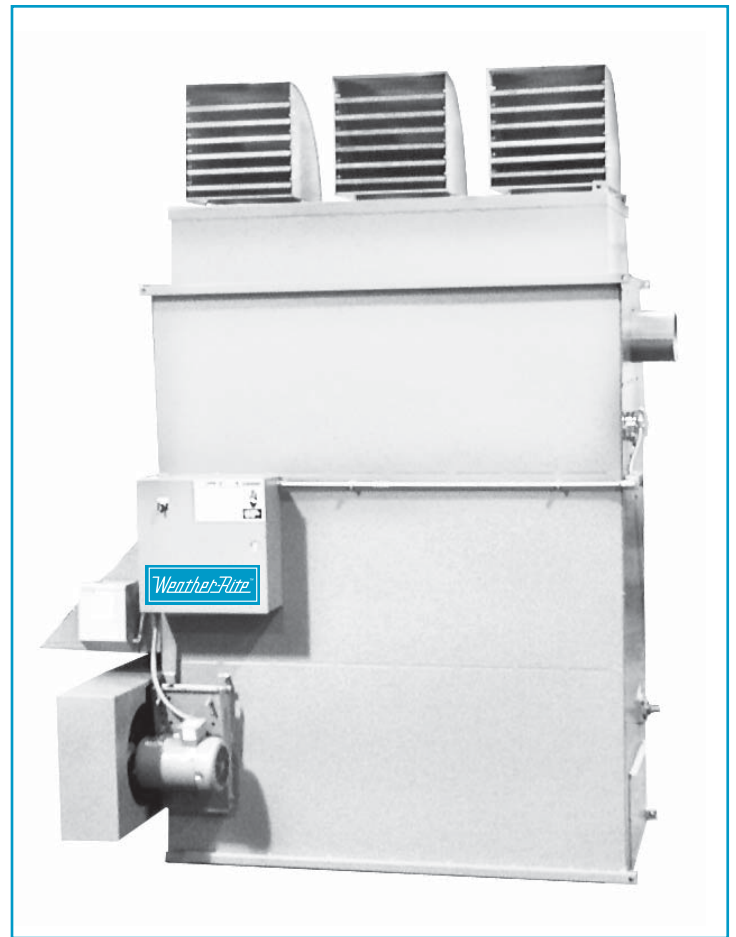

***612.338.1401***



# WEATHER-RITE™ IDF-Series

WEATHER-RITE™ IDF-Series air handlers improve indoor air quality and provide air comfort.

WEATHER-RITE™ IDF-Series is one of the most versatile indirect-fired heating systems. With three fuel options, three control options, nine discharge choices, horizontal or upright installation, plus a complete line of air handling and filtering accessories, WEATHER-RITE™ IDF-Series is designed to last for years with proper installation, maintenance and use.

MODEL	IDF-35	IDF-45	IDF-50	IDF-65	IDF-75	IDF-85	IDF-100	IDF-125	IDF-150
CFM	3,500-6,000	3,500-6,000	4,000-8,000	4,000-8,000	6,000-12,000	6,000-12,000	6,000-12,000	10,000-18,000	13,000-24,000
Output [MBH]*	240-350	240-450	240-500	520-650	520-750	520-850	520-1,000	560-1,250	560-1,500

MODEL	IDF-175	IDF-200	IDF-225	IDF-250	IDF-275	IDF-300	IDF-350	IDF-400	IDF-450
CFM	13,000-24,000	21,000-37,000	21,000-37,000	21,000-45,000	21,000-45,000	30,000-45,000	35,000-57,000	35,000-57,000	35,000-57,000
Output [MBH]*	600-1,750	600-2,000	600-2,250	600-2,500	720-2,750	720-3,000	720-3,500	1,400-4,000	1,400-4,500

\* 1 MBH = 1,000 Btu/h

## Model Configurations

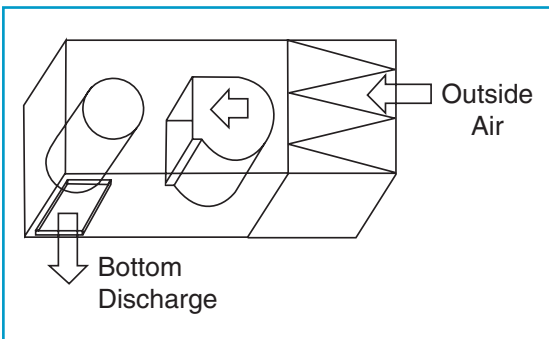

### Make-Up Air (MUA) Models

**Design:** 100% replacement air with a fixed discharge air volume.

**Function:** Supplies direct replacement air for building mechanical exhaust.

**Application:** Used as make-up air for paint booths and other industrial processes which incorporate mechanical exhaust.

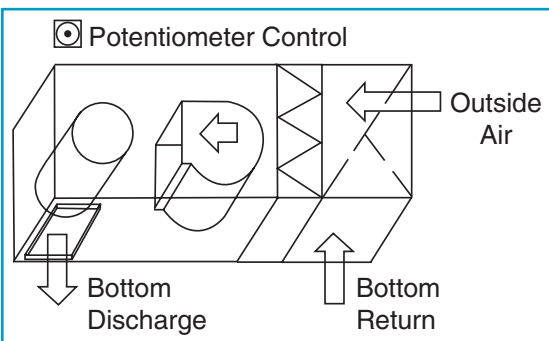

### Fixed Recirculation (FR) Models

**Design:** Manual modulation of outdoor air from 0% to 100% with use of mixing box and potentiometer.

**Function:** Provides efficient, low-cost heating where minimum ventilation rates are required.

**Application:** Used in warehouses, distribution centers, retail outlets, etc.

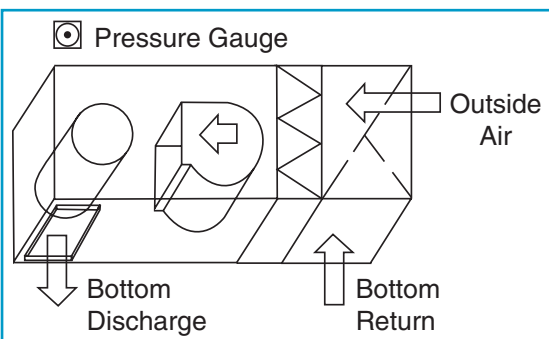

### Air Management (AM) Models

**Design:** Automatic modulation of outdoor air from 0% to 100% with use of mixing box and pressure gauge.

**Function:** Automatically responds to building pressure and temperature needs.

**Application:** Used in industrial and commercial buildings that have air quality and specific air management requirements.

# WEATHER-RITE™ IDF-Series Features

---

## Reliable, Efficient System Operation Provided by:

- Double-width, double-inlet, forward-curved Class I, AMCA rated centrifugal fan.
- System that does not contaminate heated air with combustion by-products.
- Operation of fan only in warm weather to enjoy free ventilation cooling.
- Full-floating, stainless steel primary heat exchanger.
- Multiple blowers on tubular steel blower shafts (on most models).
- Mounting and wiring of all necessary operating starters, relays, switches, safety controls and fuses.
- Variable pitch drive pulley (up through 10 hp).
- ODP motors with adjustable motor mounts.

## Long Lasting Construction Provided by:

- Rugged angle steel base frame on every unit section to withstand the rigors of shipping and handling.
- Fabricated sheet panels that virtually eliminate rattling or rumbling.
- Extra long life, self-aligning bearings sized for industrial duty.
- White painted finish.
- Double-wall heat exchanger module.

## Ease of Maintenance Provided by:

- Modular designed sections.
- Convenient access to heat exchangers and blower module for field service.
- Optional service platforms on upright units.

## Other IDF-Series Options:

- Natural gas, propane gas or oil burners available.
- Roof curbs and vertical stands simplify mounting.
- Fresh air hood with birdscreen helps protect against water entrainment.
- V-bank filter section with disposable or cleanable filters for longer equipment life of internal components.
- Motorized two-position inlet or discharge damper for exfiltration control.
- Gas trains approved to FM, IRI, or other special code requirements.
- Insulated and/or weatherized sections available for outdoor units.

## IDF-Series Controls' Options:

- Remote Station with room or discharge thermostat for easy operation and remote temperature adjustment.
- UL listed.
- Audible alarm for flame failure.
- Clogged filter indicator.
- Service Receptacle.
- Unit-mounted on/off toggle switch.

# WEATHER-RITE™ IDF-Series Optional Cooling Packages

---

## Evaporative Cooling

WEATHER-RITE™ IDF-Series evaporative cooling system is an economical cooling solution. It requires no air-cooled condenser, no chiller or cooling tower, no chilled water pumps or distribution piping/insulation, no major motor control center or electrical gear. Operating costs are a fraction of similar-capacity mechanical refrigeration systems.

Evaporative cooling works when warm air passes over specially treated wetted media. The heat passes from the air to the wetted media, causing the water to evaporate and inside air to cool.

## Mechanical Cooling

For situations requiring temperature and humidity levels lower than the performance parameters available with outdoor air alone or with evaporative cooling, WEATHER-RITE™ IDF-Series offer a broad range of cooling options.

Cooling options can be added by simply installing coil sections equipped with the appropriate cooling coils and a condensing unit or chiller. The versatility afforded by the coil section enables you to utilize DX refrigerant, chilled water or other types of cooling coils in your system.

# Discharge Options

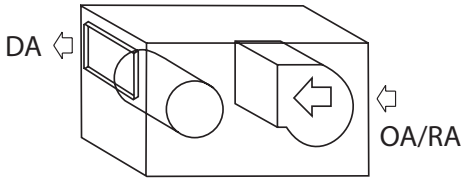
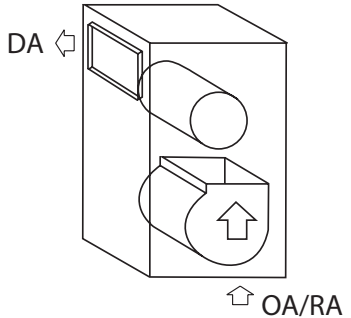
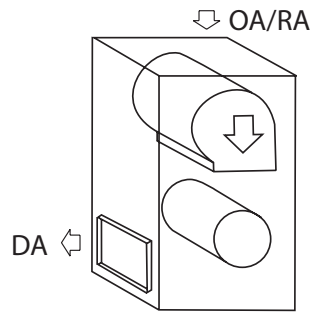
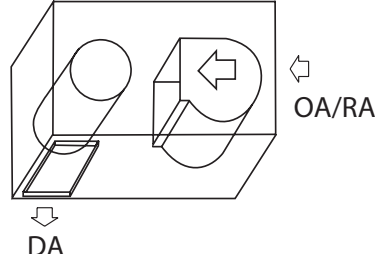
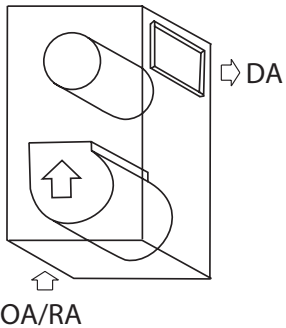
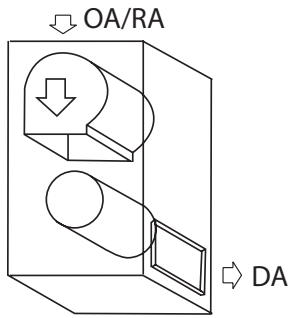
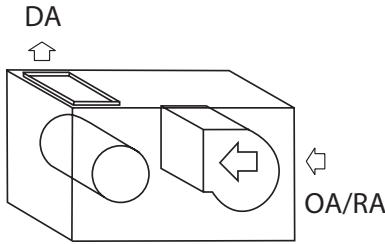
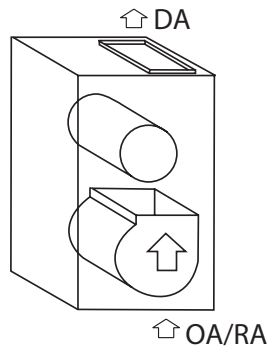
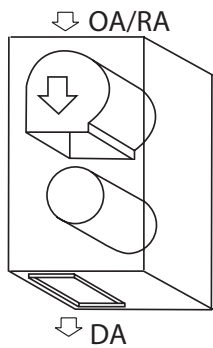
Horizontal Unit/Horizontal Discharge	Upright Unit/Top Left Discharge	Upright Unit/Bottom Left Discharge
		
Horizontal Unit/Bottom Discharge	Upright Unit/Top Right Discharge	Upright Unit/Bottom Right Discharge
		
Horizontal Unit/Top Discharge	Upright Unit/Top Discharge	Upright Unit/Bottom Discharge
		
LEGEND		
OA = Outside Air	DA = Discharge Air	RA = Return Air

## Installation Code and Annual Inspections:

All installations and service of WEATHER-RITE™ products must be performed by a contractor qualified in the installation and service of products sold and supplied by Weather-Rite LLC and conform to all requirements set forth in the WEATHER-RITE™ manuals and all applicable governmental authorities pertaining to the installation, service and operation of the equipment. To help facilitate optimum performance and safety, Weather-Rite LLC recommends that a qualified contractor annually inspect your WEATHER-RITE™ products and perform service where necessary, using only replacement parts sold and supplied by Weather-Rite LLC.

**Further Information:** Applications, engineering and detailed guidance on system design, installation and product performance is available through WEATHER-RITE™ representatives. Please contact us for any further information you may require, including the Installation, Operation and Service Manual.

**This product is not for residential use.**

This document is intended to assist licensed professionals in the exercise of their professional judgement.

## Weather-Rite LLC

616 North 5th Street  
 Minneapolis, MN 55401  
 Telephone: 612.338.1401  
 Fax: 612.338.6783

[www.weather-rite.com](http://www.weather-rite.com)

© 2007 Roberts-Gordon, LLC All rights reserved. No part of this work covered by the copyrights herein may be reproduced or copied in any form or by any means – graphic, electronic, or mechanical, including photocopying, recording, taping, or information storage and retrieval systems – without written permission of Roberts-Gordon, LLC.