

# Weather-Rite LLC

## Weather-Rite™ GH

### Residential and Commercial Low-intensity Infrared Heater

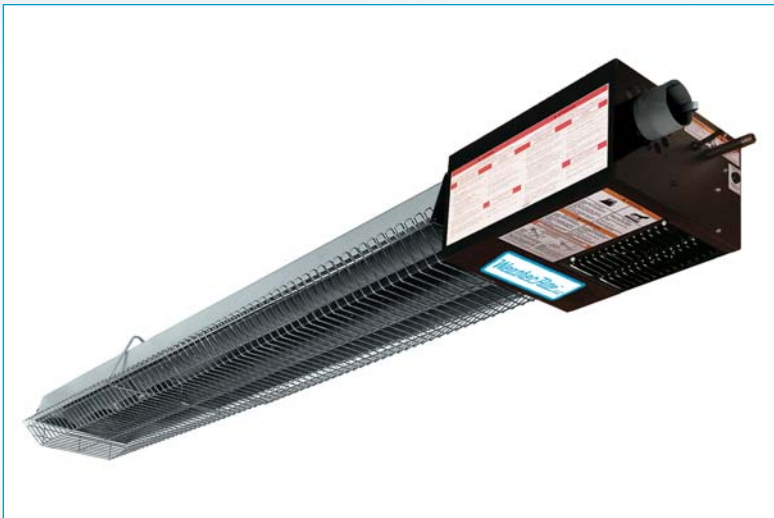

- Approved for residential and commercial applications
- Factory-assembled for easy installation
- Longer life provided by durable components
- Compact U-tube design provides maximum inputs at minimum lengths
- One building penetration-balanced flue for both exhaust and combustion air
- Ceiling-mounted to free valuable work space below

CUT ENERGY  
BILLS BY UP TO  
**50%**  
with  
**WEATHER-RITE**  
[www.weather-rite.com](http://www.weather-rite.com)

**1.800.589.3691**  
**[www.weather-rite.com](http://www.weather-rite.com)**



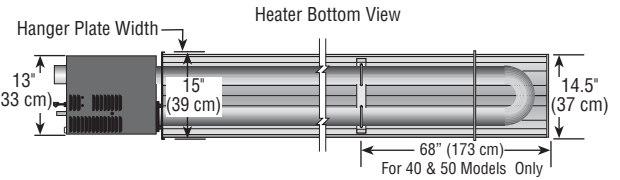
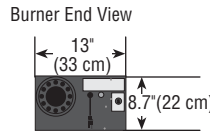
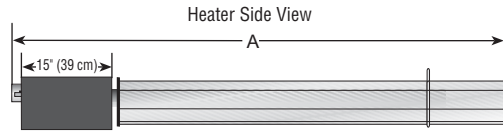

## Weather-Rite™ GH

Model		CGTH-30	CGTH-40	CGTH-50
Overall Length	[ft, in] A	8', 0"	11', 6"	11', 6"
Weights	[lb]	85	96	96
Input (Btu/h) x (1,000)		30	40	50
Fuel		Natural Gas (NG) or Propane Gas (LP)		
Inlet Pressure	[in wc] NG min. LPG Propane min. NG & LPG Propane max.	5 11 14		
Gas Connection	NPT	3/8" (3/8" Manual Shut-off Valve Included with Heater)		
Minimum Mounting Height	[ft]*	7' (Required Safe Distance from Combustibles Must be Maintained)		
Electrical Supply		120 V, 60 Hz, 1 Ø, 1 A (Connection - Cord with 3-Prong Molded Plug)		
Thermostat		Low Voltage, 24 Vac Dual Scale Included with Heater (120 Vac Optional) (Connection - Built-in Receptacle on Heater)		
Heat Exchanger Tubing		3" dia, 16 Gauge, Heat Treated ALUMI-THERM® Steel Tubing		
Exhaust Flue/Vent OD	[in]	3" dia/5" dia (Included with Heater)		
Balanced Flue		Vent Collar and Vent Termination Included with Heater		
Flue Length	[ft, in]	2', 6" Minimum; 10', 0" Maximum		
Reflector and End Caps		.024 Mill Finish Aluminum		
Ignition		Fully Automatic, Three Try, Direct Spark Electronic Ignition Control, 100% Shut-Off		
Approved As		Indoor Vented Overhead Room Heater		
CSA Standards		ANSI Z21.86 / CSA 2.32		
Warranty		Three-Year Limited (Refer to Installation, Operation and Service Manual for details)		
Options		Roof Venting Kit, 90° Elbow Kit, Wall Venting Kits		

\*The minimum mounting height is 10 ft (3 m) for aircraft hangars and 8 ft (2.4) for public garages.

### Required Safe Distance from Combustibles \*\*[in]

Model	CGTH-30	CGTH-40	CGTH-50
A	4	4	4
B	16	18	20
C	36	48	48
D	28	30	32
E	34	34	36
F	6	6	6

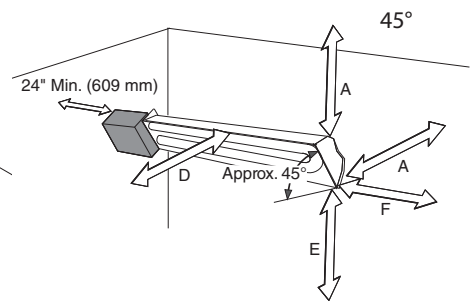
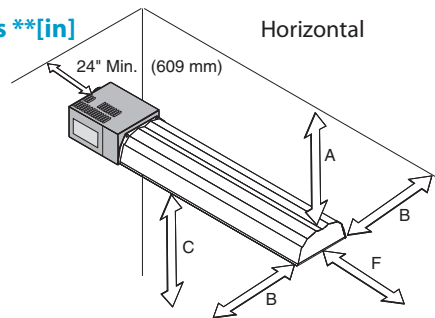

\*\* For complete installation, operation and service criteria, please see the current issue of the Installation, Operation and Service Manual.

### Installation Code and Annual Inspections:

All installations and service of WEATHER-RITE™ equipment must be performed by a contractor qualified in the installation and service of equipment sold and supplied by Weather-Rite LLC and conform to all requirements set forth in the WEATHER-RITE™ manuals and all applicable governmental authorities pertaining to the installation, service and operation of the equipment. To help facilitate optimum performance and safety, Weather-Rite LLC recommends that a qualified contractor annually inspect your WEATHER-RITE™ equipment and perform service where necessary, using only replacement parts sold and supplied by Weather-Rite LLC.

**Further Information:** Applications, engineering and detailed guidance on systems design, installation and equipment performance is available through WEATHER-RITE™ representatives. Please contact us for any further information you may require, including the Installation, Operation and Service Manual.

**This document is intended to assist licensed professionals in the exercise of their professional judgement.**

### Weather-Rite LLC

616 North 5th Street  
 Minneapolis, MN 55401  
 Telephone: 612.338.1401  
 Fax: 612.338.6783  
 Toll Free: 1.800.589.3691  
[www.weather-rite.com](http://www.weather-rite.com)

© 2008 Weather-Rite LLC

All rights reserved. No part of this work covered by the copyrights herein may be reproduced or copied in any form or by any means – graphic, electronic, or mechanical, including photocopying, recording, taping, or information storage and retrieval systems without written permission of Weather-Rite LLC.